

AVENUE

Avenue™ signal integration system

Model 5385 Analog to Digital Converter Data Pack

ENSEMBLE
DESIGNS

Revision 1.1 SW v2.2.0

This data pack provides detailed installation, configuration and operation information for the **5385 Analog to Digital Video Converter** module as part of the Avenue Signal Integration System.

The module information in this data pack is organized into the following sections:

- 5385 Overview
- Applications
- Installation
- Cabling
- Module Configuration and Control
 - Front Panel Controls and Indicators
 - Avenue PC Remote Control
 - Avenue Touch Screen Remote Control
- Troubleshooting
- Software Updating
- Warranty and Factory Service
- Specifications

5385 OVERVIEW

The 5385 module converts analog composite video to serial digital video. Twelve bit processing and 4x oversampling ensure clean signals that can be used in the most demanding applications.

The input is digitally decoded with sophisticated filtering to cleanly separate chroma and luminance content. The user selectable adaptive comb filter can be set to 3 line or 5 line mode. Complete proc amp controls provide adjustment for video, chroma, setup, and hue. The SDI output is synchronous with respect to the analog input.

Because the 5385 is an Avenue module, every function and parameter can be controlled from an Avenue Touch Screen, Express Control Panel, or the Avenue PC Control Application.

Module memory registers can be used to save the complete configuration of the module, making it easy to change instantly between different configurations.

Modules at software version 2.2.0 or later support SNMP (Simple Network Management Protocol) monitoring. For each applicable signal processing module, module, signal, and reference status are reported. For complete details on using SNMP monitoring, refer to the **Avenue System Overview** in the manual that accompanies each frame.

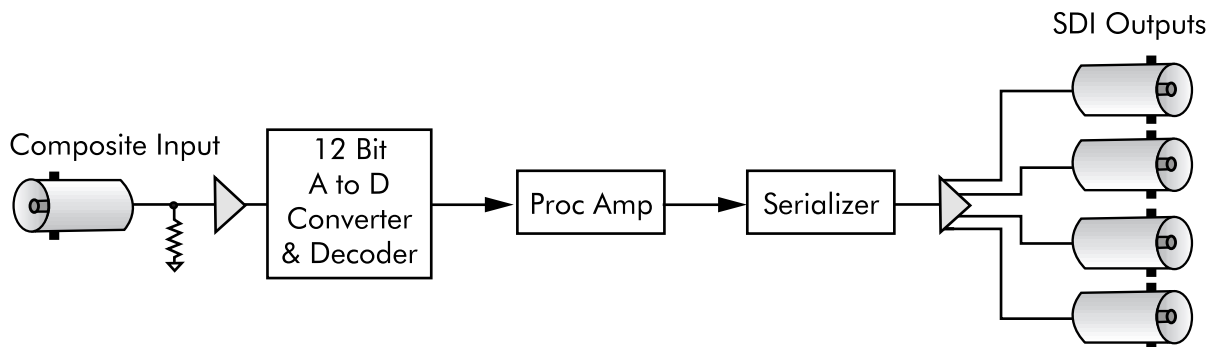

5385 A-D Converter Functional Block Diagram

APPLICATIONS

As illustrated in the block diagram below, the 5385 can convert an analog composite signal from a genlocked camera for example to four SDI video outputs that will feed other genlocked digital devices in the facility such as digital router, digital switcher and a video server. The SDI outputs from the 5385 are synchronous with respect to the analog video input.

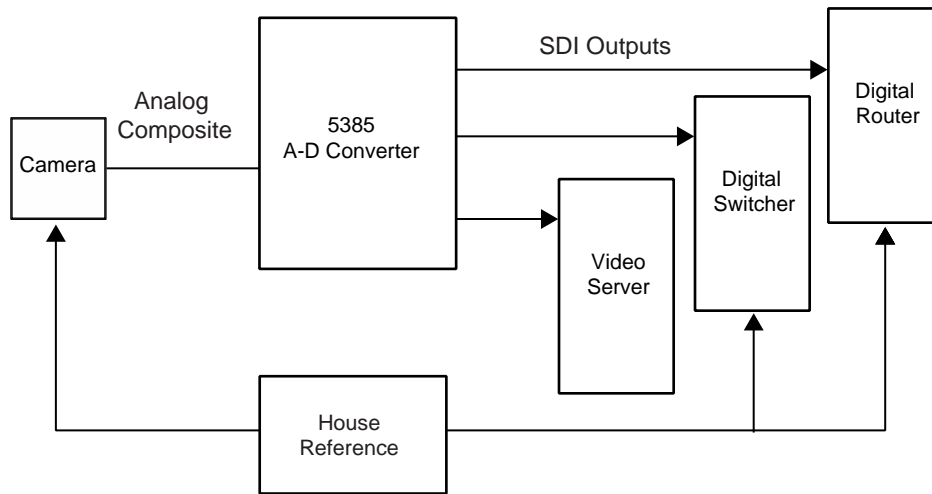

5385 A-D Converter Application

INSTALLATION

5385 ADC Module

Plug the 5385 module into any one of the slots in the 1 RU or 3 RU frame and install the plastic overlay provided onto the corresponding group of rear BNC connectors associated with the module location. Note that the plastic overlay has an optional adhesive backing for securing it to the frame. Use of the adhesive backing is only necessary if you would like the location to be permanent and is not recommended if you need to change module locations. This module may be hot-swapped (inserted or removed) without powering down or disturbing performance of the other modules in the system.

CABLING

Refer to the 3 RU and 1 RU backplane diagrams of the module below for cabling instructions. Note that unless stated otherwise, the 1 RU cabling explanations are identical to those given in the 3 RU diagram.

3 RU Backplane

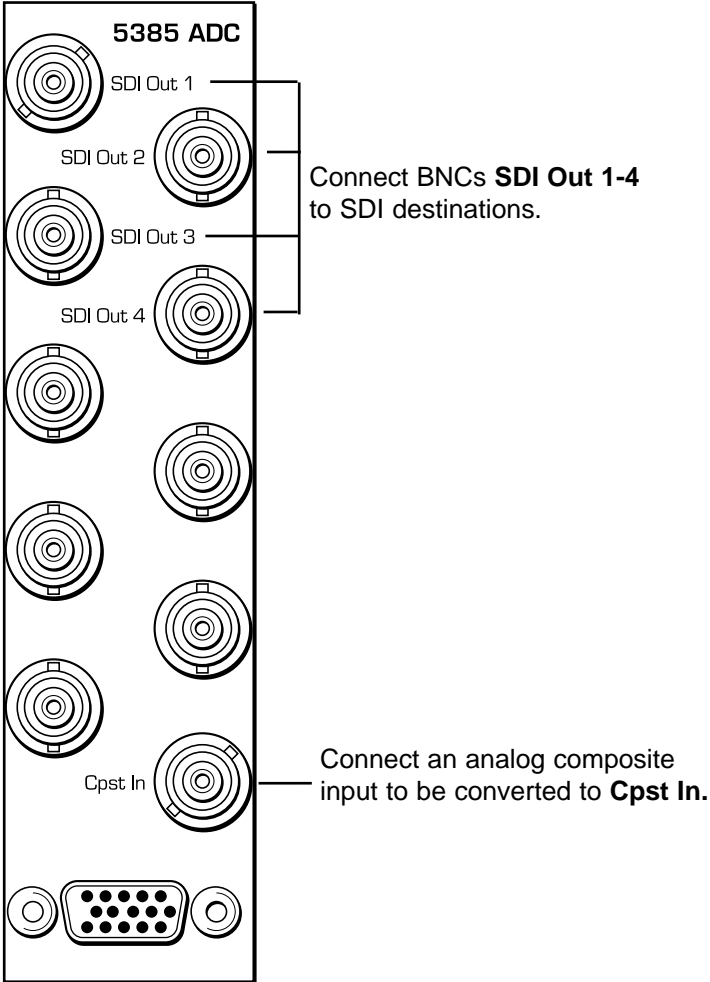

1 RU Backplane

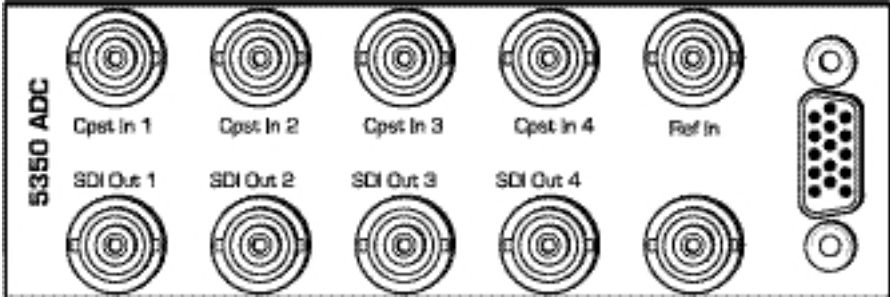

MODULE CONFIGURATION AND CONTROL

The configuration parameters for each Avenue module must be selected after installation. This can be done remotely using one of the Avenue remote control options or locally using the module front panel controls. Each module has a **REMOTE/LOCAL** switch on the front edge of the circuit board which must first be set to the desired control mode.

The configuration parameter choices for the module will differ between **Remote** and **Local** modes. In **Remote** mode, the choices are made through software and allow more selections. The **5385 Parameter Table** later in this section summarizes and compares the various configuration parameters that can be set remotely or locally and the default/factory settings. It also provides the default User Levels for each control. These levels can be changed using the Avenue PC application.

If you are not using a remote control option, the module parameters must be configured from the front panel switches. Parameters that have no front panel control will be set to a default value. The **Local** switches are illustrated in the **Front Panel Controls and Indicators** section following the **5385 Parameter Table**.

Avenue module parameters can be configured and controlled remotely from one or both of the remote control options, the Avenue Touch Screen or the Avenue PC Application. Once the module parameters have been set remotely, the information is stored on the module CPU. This allows the module to be moved to a different cell in the frame at your discretion without losing the stored information. Remote configuration will override whatever the switch settings are on the front edge of the module.

For setting the parameters remotely using the Avenue PC option, refer to the **Avenue PC Remote Configuration** section of this document.

For setting the parameters remotely using the Avenue Touch Screen option, refer to the **Avenue Touch Screen Remote Configuration** section of this document following Avenue PC.

Express Panel operation is described in the data pack that accompanies the control panel option.

5385 Parameter Table

CONTROL	LOCAL	REMOTE	FACTORY DEFAULT	DEFAULT USER LEVEL
Blanking	Wide	Narrow (PAL Lines 1-6< NTSC Lines 1-9) Wide (PAL Lines 1-22< NTSC Lines 1-20)	Wide	Admin
Setup Removal	On	Off On	On	Admin
Comb Filter	3 Line	3 Line 5 Line	3 Line	Level 1
Gain	100%	0 – 150%	100%	Admin
Chroma	100%	0 – 150%	100%	Admin
Pedestal	0 IRE	+/- 30 IRE	0 IRE	Admin
Hue	0 IRE	+/- 180 degrees	0 degrees	Admin

Front Panel Controls and Indicators

Each front edge indicator and switch setting is shown in the diagram below:

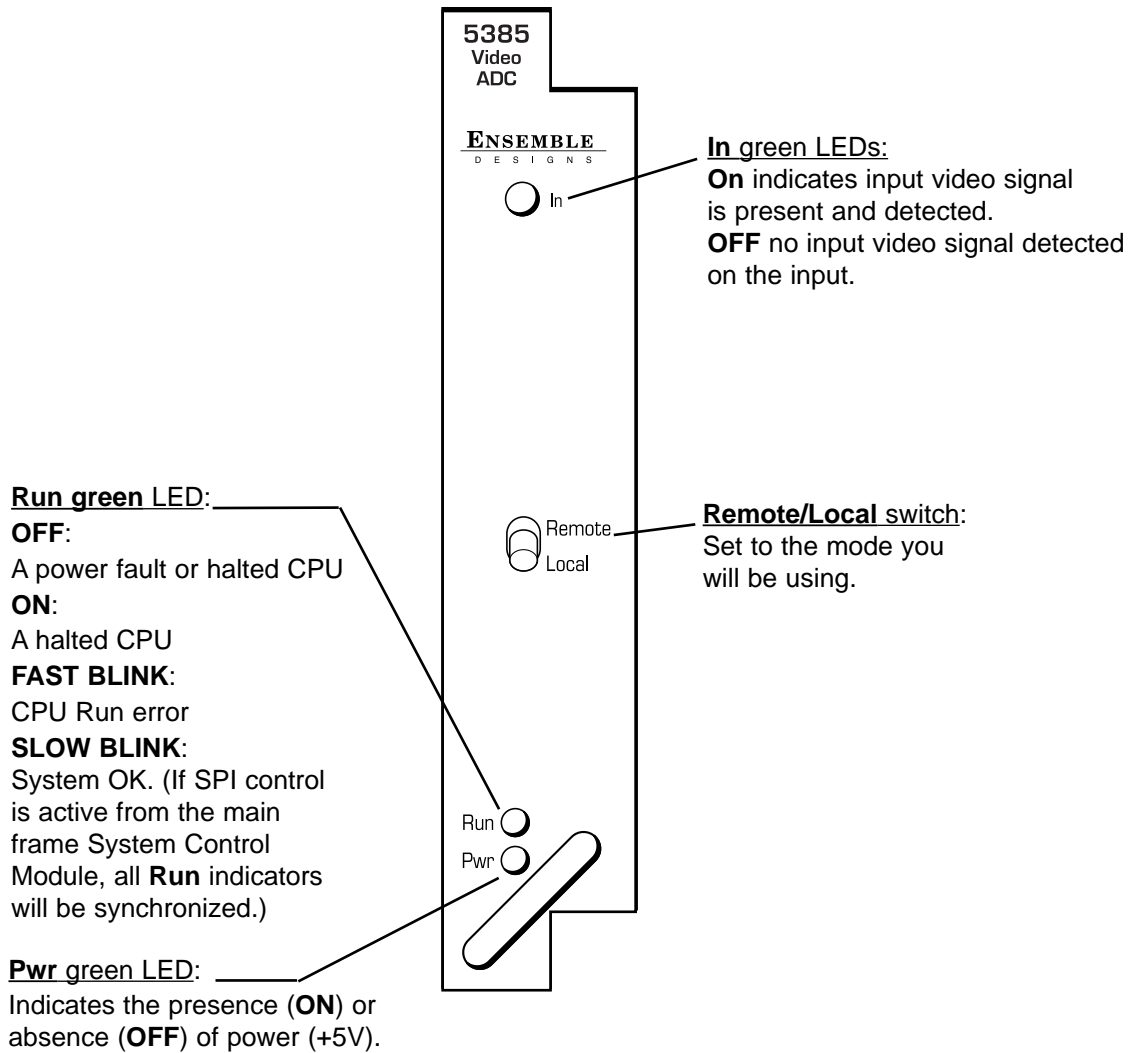

Avenue PC Remote Configuration

The Avenue PC remote control menus for this module are illustrated and explained below. Refer to the **5385 Parameter Table** for a summary of available parameters that can be set remotely through the menus illustrated.

Parameter fields that are grayed out can indicate one of the following conditions:

- An option is not installed.
- The function is not active.
- The module is locked.
- The User Level set with Avenue PC is not accessible from the current User Level.

5385 Avenue PC Menus

The **Config 1** menu shown below shows the configuration parameters available.

- **Blanking** – use this control to set the blanking for **Narrow** (lines 1-9 are blanked in NTSC, lines 1-6 in PAL) or **Wide** (lines 1-20 in NTSC, lines 1-22 in PAL).
- **Setup Removal** – use this control to turn setup removal on or off depending on the requirement of the input signal.
- **Comb Mode** – set the comb mode for **3 Line** (best for video with motion) or **5 Line** decoding.

Status reporting is provided for the following conditions:

- **Input** – reports the input status as **No Input**, **525 Lock**, or **625 Lock**.

The screenshot displays the 'Config 1' menu with three tabs: 'Config 1', 'Proc 1', and 'Memory'. The 'Config 1' tab is active. The menu contains four configuration fields:

- Input:** A text field displaying 'No Input'.
- Blanking:** A dropdown menu currently set to 'Narrow'.
- Setup Removal:** A dropdown menu currently set to 'On'.
- Comb Mode:** A dropdown menu currently set to '5 Line'.

The **Proc 1** menu shown below has the following controls for adjusting video processing parameters:

- **Gain** – adjust the percentage of overall gain (luminance and chrominance).
- **Chroma** – adjust the percentage of chroma amplitude.
- **Pedestal** – adjust the pedestal (black) level of the signal in IRE.
- **Hue** – adjust the hue of the signal ± 180 degrees.

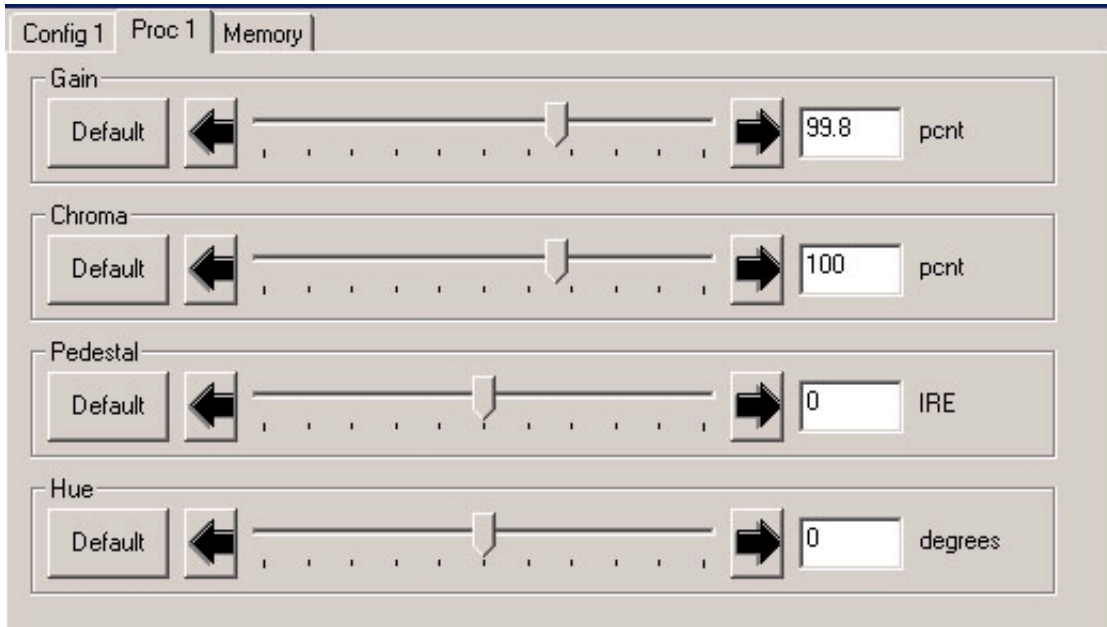

The **Memory** menu shown below allows you to save overall module setups to five memory registers as follows:

- Select **Save**, then one of the five memory registers **Reg 1 – 5**. The box will turn green. The entire module setup is now saved in the selected register.
- To recall a register, select the register box. If there is information saved, the box will turn green. The saved setup will now be loaded to the module. Up to five different module setups can be saved and recalled using the individual registers.



Avenue Touch Screen Remote Configuration

The Avenue Touch Screen remote control menus for this module are illustrated and explained below. Refer to the **5385 Parameter Table** for a summary of available parameters that can be set remotely through the menus illustrated.

Parameter fields that are grayed out can indicate one of the following conditions:

- An option is not installed.
- The function is not active.
- The module is locked.
- The User Level set with Avenue PC is not accessible from the current User Level.

5385 Touch Screen Menus

The **Config 1** menu shown below shows the configuration parameters available.

- **Blanking** – use this control to set the blanking for **Narrow** (lines 1-9 are blanked in NTSC, lines 1-6 in PAL) or **Wide** (lines 1-20 in NTSC, lines 1-22 in PAL).
- **Setup Removal** – use this control to turn setup removal on or off depending on the requirement of the input signal.
- **Comb Mode** – set the comb mode for **3 Line** (best for video with motion) or **5 Line** decoding.

Status reporting is provided for the following conditions:

- **Input** – reports the input status as **No Input**, **525 Lock**, or **625 Lock**.

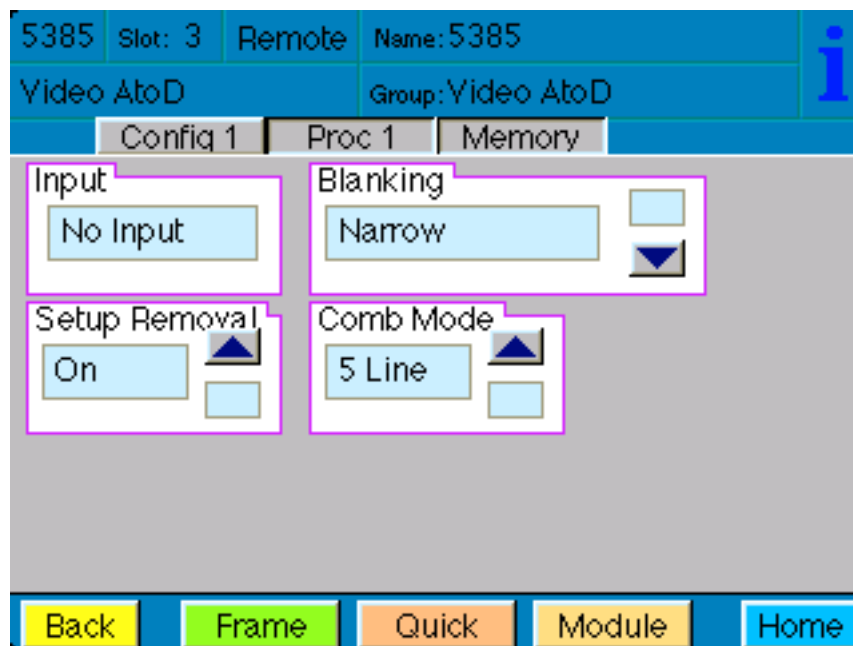

The **Proc 1** menu shown below gives an example of the adjustable video processing parameters for each channel in their respective Proc 1-4 menus:

- **Gain** – adjust the percentage of overall gain (luminance and chrominance).
- **Chroma** – adjust the percentage of chroma amplitude.
- **Pedestal** – adjust the pedestal (black) level of the signal in IRE.
- **Hue** – adjust the hue of the signal ± 180 degrees.

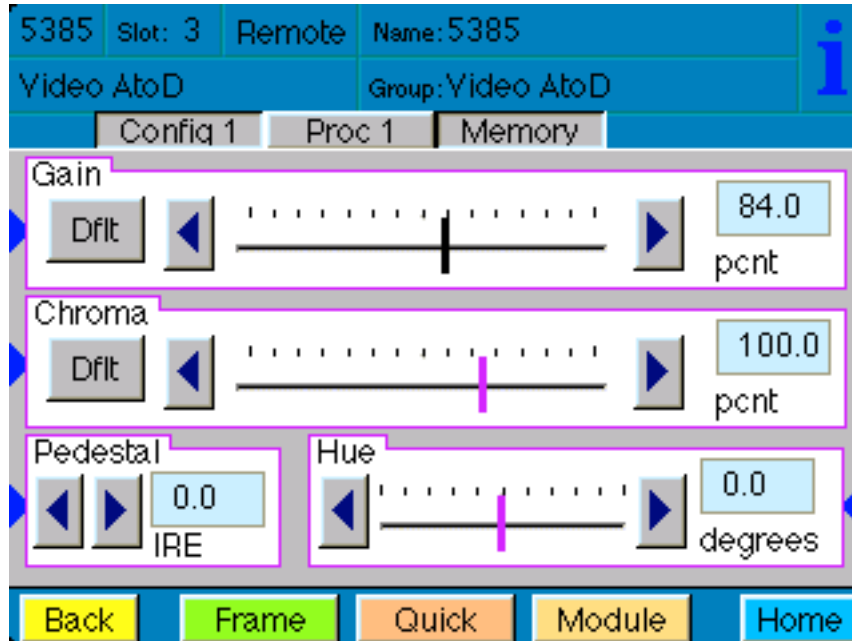

The **Memory** menu shown below allows you to save overall module setups to five memory registers as follows:

- Select **Save**, then one of the five memory registers **Reg 1 – 5**. The box will turn green. The entire module setup is now saved in the selected register.
- To recall a register, select the register box. If there is information saved, the box will turn green. The saved setup will now be loaded to the module. Up to five different module setups can be saved and recalled using the individual registers.

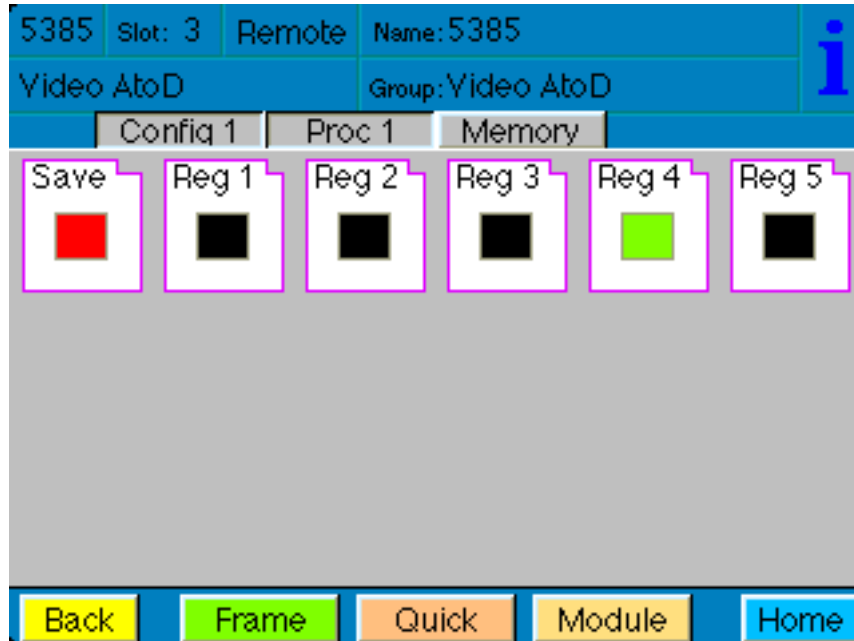

TROUBLESHOOTING

As a troubleshooting aid, the reference signal status and presence, power and CPU status can be easily monitored from the front panel of this module using the front panel indicators.

Refer to the overall troubleshooting tips given below for the module:

Can't control module:

- Check status of CPU **Run** green LED. Should be blinking slowly and in unison with other modules if System module is present. If not, try removing it and plugging it in again to be sure it is seated properly.
- System module may not be working properly if installed.

Module controls are grayed out:

- Module is locked or access to module controls is restricted by User Level.
- Local/Remote switch on module is in the **Local** position.

No signals out of module:

- Check status of **In** LED. It should be lit. If not, check input for presence and quality.
- Check cabling to input of module.
- Check inputs to destinations are terminated properly.

You may also refer to the technical support section of the Ensemble Designs web site for the latest information on your equipment at the URL below:

<http://www.ensembledesigns.com/support>

SOFTWARE UPDATING

Software upgrades for each module can be downloaded remotely if the optional System Control module is installed. These can be downloaded onto your PC and then Avenue PC will distribute the update to the individual module. (Refer to the Avenue PC documentation for more information). Periodically updates will be posted on our web site. If you do not have the required System Control Module and Avenue PC, modules can be sent back to the factory for software upgrades.

WARRANTY AND FACTORY SERVICE

Warranty

This module is covered by a five year limited warranty, as stated in the main Preface of this manual. If you require service (under warranty or not), please contact Ensemble Designs and ask for customer service before you return the unit. This will allow the service technician to provide any other suggestions for identifying the problem and recommend possible solutions.

Factory Service

If you return equipment for repair, please get a Return Material Authorization Number (RMA) from the factory first.

Ship the product and a written description of the problem to:

Ensemble Designs, Inc.

Attention: Customer Service RMA #####

870 Gold Flat Rd.

Nevada City, CA. 95959 USA

(530) 478-1830

Fax: (530) 478-1832

service@ensembledesigns.com

<http://www.ensembledesigns.com>

Be sure to put your RMA number on the outside of the box.

SPECIFICATIONS

5385 Video A-D Converter

Analog Video Input

Type	NTSC, PAL Composite
Impedance	75 Ω , BNC
Return Loss	> 40 dB, DC to 5.5 MHz
Input DC	\pm 1 volt DC
Input Hum	< 100 mV

Serial Digital Outputs

Number	Four
Type	SMPTE 259M
Impedance	75 Ω , BNC
Return Loss	> 15 dB
Output DC	None (AC coupled)

Analog Video to SDI Performance

Bit Resolution	12 bit input quantization 4x Oversampling
Decoding	Adaptive Comb Filter 3 or 5 line selectable
Signal to Noise	> 62 dB, weighted
Frequency Response	\pm 0.1dB, 0 to 5.5 MHz

General

Power Consumption	< 7 watts
Temperature	0 to 40° C ambient (all specifications met)
Relative Humidity	0 to 95%, noncondensing
Altitude	0 to 10,000 ft.

Due to ongoing product development, all specifications subject to change.