

AVENUE

Avenue™ signal integration system

Model 5640 AES Audio Mix and Shuffle Data Pack

ENSEMBLE

D E S I G N S

Revision 2.1 SW v1.1.2

This data pack provides detailed installation, configuration and operation information for the **5640 AES Audio Mix/Shuffle** module as part of the Avenue Signal Integration System.

The module information in this data pack is organized into the following sections:

- Module Overview
- Applications
- Installation
- Cabling
- Module Configuration and Control
 - Front Panel Controls and Indicators
 - Avenue PC Remote Control
 - Avenue Touch Screen Remote Control
- Troubleshooting
- Software Updating
- Warranty and Factory Service
- Specifications

MODULE OVERVIEW

The 5640 AES Audio Mix and Shuffle module is four channel with AES inputs and outputs. The module provides two AES audio inputs, supporting 20 or 24 bit inputs, and two AES audio outputs (two copies of each). The AES signal path is 24-bit. A 4-Channel mixer provides full swapping and shuffling functionality through the control system via the Avenue Touch Screen and Avenue PC. Individual level controls are available over 4 inputs: 4 analog or 2 AES. Level controls are available on the outputs as well. Each of the 4 output channels has a source selector. Phase control, or invert, is also provided.

Analog audio I/O support is available with optional daughter cards. There are three optional daughter cards available: the 5610 providing 4 Channel Analog Inputs; the 5611 providing 4 Channel Analog Outputs; and the 5612 for 2 Channel Analog Inputs and 2 Channel Analog Outputs. Only one option can be installed on a module. The analog signal path is 20-bit

As illustrated in the module block diagram below, the two AES inputs are fed to the module via BNCs on the rear backplane to AES receivers. These audio streams then enter the 4 Channel Mixer circuit where they can be mixed and shuffled as specified by the user through the Avenue Touch Screen and Avenue PC menus. The final audio passes through AES transmitter circuitry and is then sent to the two AES output BNCs. Additional BNCs provide copies of each audio output.

Power is derived from the ± 12 volt frame power. It is regulated to the required +5 volts for the digital circuitry by on-board regulators. The required +3 volts for the multiplexer circuitry is developed in a linear regulator running off the +5 volt supply. The module is fused with a resettable fuse device. If the fuse opens due to an overcurrent condition, the module will lose power. After pulling the module, the fuse will reset automatically requiring no replacement fuse.

The on-board CPU can monitor and report module ID information (slot location, software version and board revision), and power status (+5 volts or +3 volts) to the optional frame System Control module. This information can be accessed by the user or set to register an alarm if desired using the remote control options available.

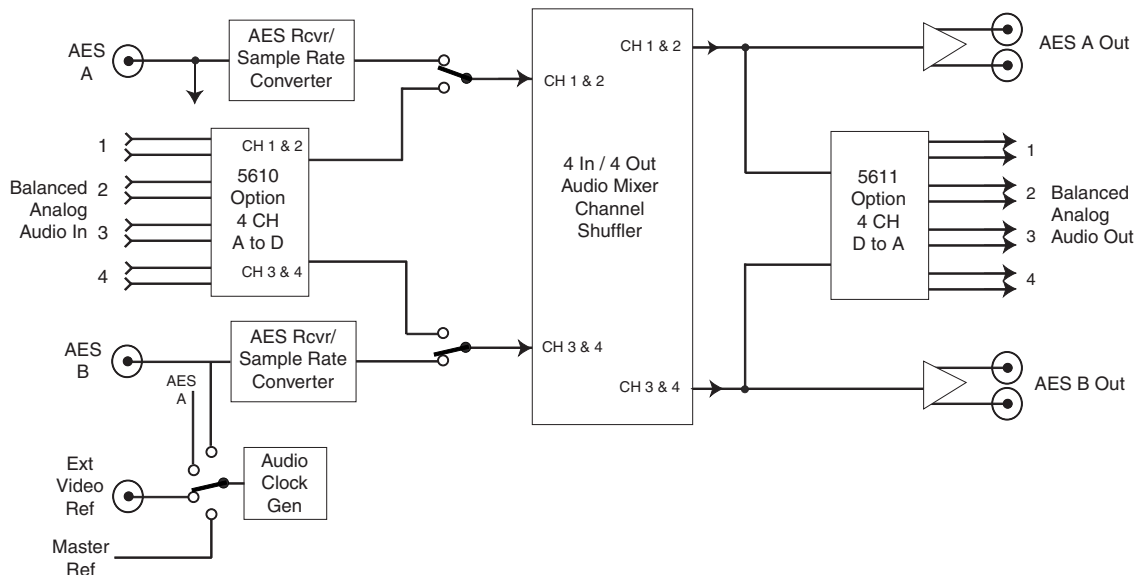

5640 Audio Mix Functional Block Diagram

APPLICATIONS

The 5640 module with the 5610 4 Channel Analog Audio option installed can be utilized to convert analog audio outputs from a VTR to AES digital audio as shown below. The audio can then be adjusted on the 5640 module for gain, channel mix and shuffle.

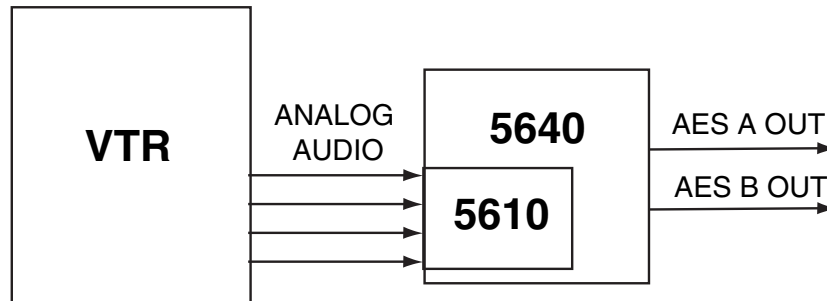

5640 With 5610 Option for Analog to Digital Conversion

Another application for the 5640 with 5610 option allows you to select from different input sources, both digital or analog as shown in the example below. The audio can also be adjusted on the 5640 module for gain, channel mix and shuffle.

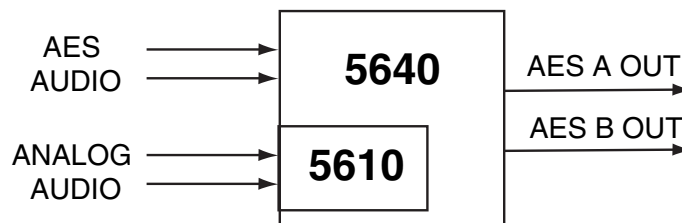

5640 With 5610 Option for Using Digital and Analog Input Sources

INSTALLATION

To install either the 5610, 5611 or 5612 daughter card option, line up the connector on the solder side of the daughter card with the the connector on the component side of the 5640 circuit board. When the connectors are aligned, press down firmly to seat the daughter board.

Plug the 5640 module into any slot in the 1 RU or 3 RU frame and install the plastic overlay provided onto the corresponding group of rear BNC connectors associated with the module location. Note that the plastic overlay has an optional adhesive backing for securing it to the frame. Use of the adhesive backing is only necessary if you would like the location to be permanent and is not recommended if you need to change module locations.

This module may be hot-swapped (inserted or removed) without powering down or disturbing performance of the other modules in the system.

CABLING

Refer to the 3 RU and 1 RU backplane diagrams of the module on the following page for cabling instructions. Note that unless stated otherwise, the 1 RU cabling explanations are identical to those given in the 3 RU diagram.

3 RU Backplane

Connect analog audio to the **Analog Audio (Control)** connector when either the 5610, 5611 or 5612 option is installed. Refer to the pinout diagram and the table below.

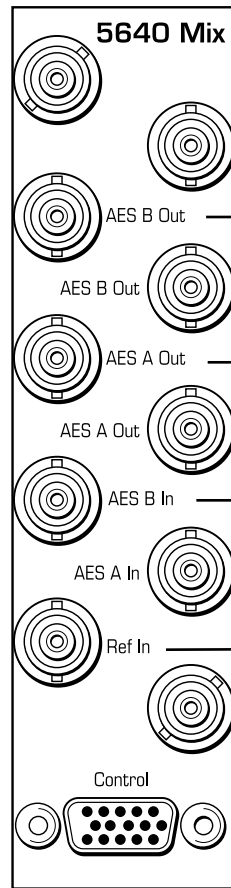
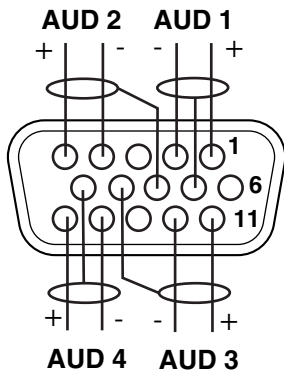

Connect the **AES A Out** and **AES B Out** BNCs to the desired audio destinations.

Connect the AES audio inputs to the **AES A In** and **AES B In** BNCs.

Connect a video reference signal to the **REF In** BNC.

ANALOG AUDIO OPTION

Signal	Pins	5610	5611	5612
Aud 1 +, -, G	1, 2, 7	Input 1	Output 1	Input 1
Aud 2 +, -, G	5, 4, 8	Input 2	Output 2	Input 2
Aud 3 +, -, G	11, 12, 9	Input 3	Output 3	Output 1
Aud 4 +, -, G	15, 14, 10	Input 4	Output 4	Output 2

1 RU Backplane

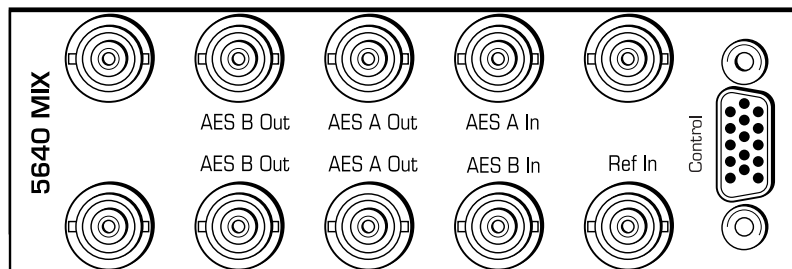

MODULE CONFIGURATION AND CONTROL

The configuration parameters for the module must be selected after installation. This is done remotely using one of the Avenue remote control options. The module has a **REMOTE/LOCAL** switch on the front edge of the circuit board which must first be set to the control mode you will be using. Set the 5640 module mode to **Remote**, there are no local controls.

The **5640 Parameter Table** below summarizes the various configuration parameters that can be set remotely and the default/factory settings.

Once the module parameters have been set remotely, the information is stored on the module CPU. This allows the module be moved to a different cell in the frame at your discretion without losing the stored information. A **Memory** function is also provided in the remote menus to allow you to store up to five module configurations in storage registers.

For setting the parameters remotely using the Avenue PC option, refer to the **Avenue PC Remote Configuration** section of this document.

For setting the parameters remotely using the Avenue Touch Screen option, refer to the **Avenue Touch Screen Remote Configuration** section of this data pack following Avenue PC.

5640 Parameter Table

CONTROL	LOCAL	REMOTE	DEFAULT/FACTORY
Reference Select	N/A	External Master	Master
In 1/2 Select	N/A	AES A Anlg 1/2 Anlg 3/4	AES A
In 3/4 Select	N/A	AES B Anlg 1/2 Anlg 3/4	AES B
Anlg Lvl 1-4	N/A	- 10 dB - 6 dB - 4 dB 0 dB + 4 dB + 8 dB	0 dB

Front Panel Controls and Indicators

Each front edge indicator and switch setting is shown in the diagram below:

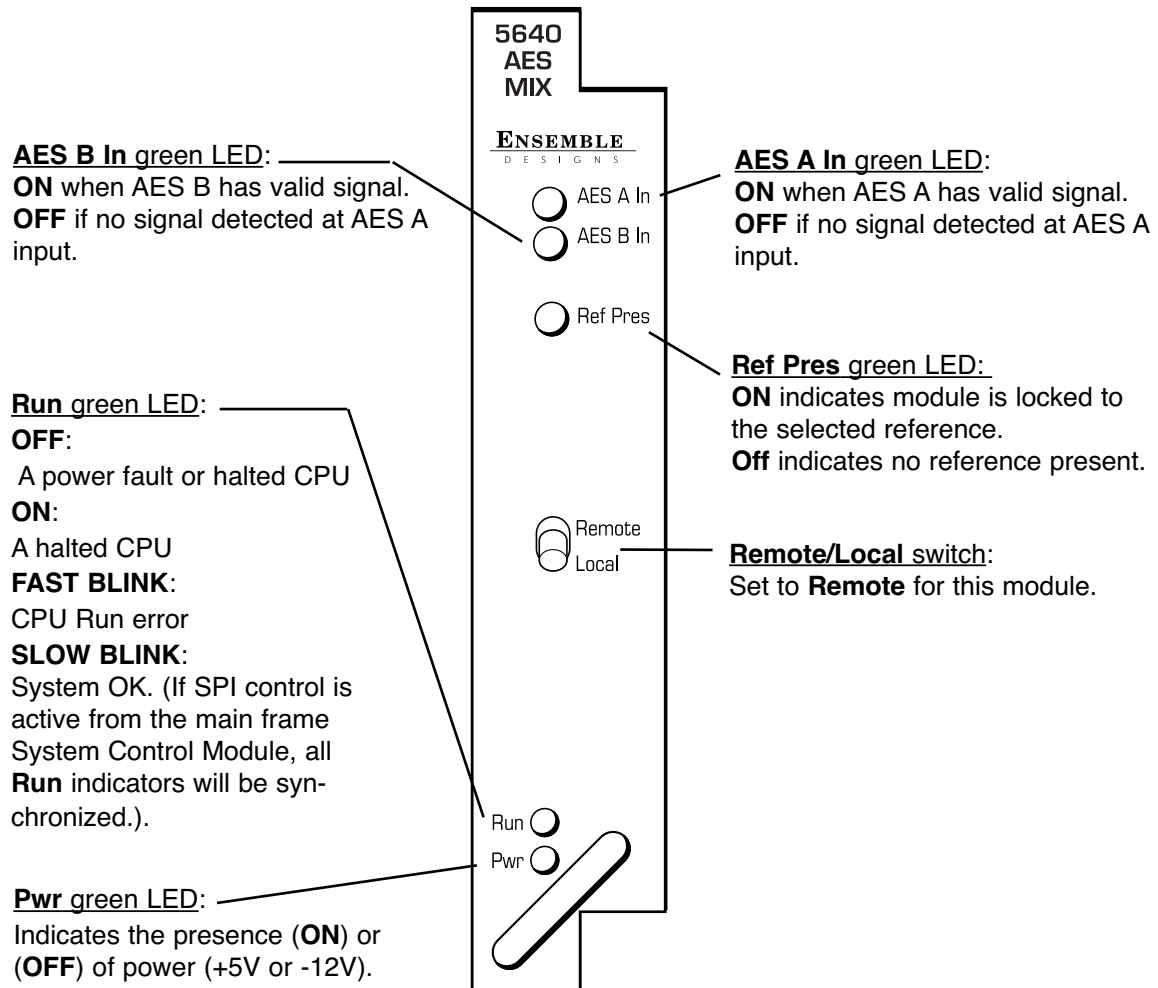

Avenue PC Remote Configuration

The Avenue PC remote control menus for this module are illustrated and explained below. Refer to the 5640 Parameter Table shown earlier for a summary of available parameters that can be set remotely through the menus illustrated. For more information on using Avenue PC, refer to the Avenue PC Control Application Software data pack that came with the option.

5640 Avenue PC Menus

Use the **Mixer** menu below to control the audio mixing and shuffling of the module. Each output bus assignment will be indicated by a green box.

- **Input Ch 1** – assign Input Channel 1 to the desired output bus or tie to Channel 2 and set the input level using the slider control or by entering a number (-70 to +6 dB) in the window.
- **Input Ch 2** – assign Input Channel 2 to the desired output bus or tie to Channel 1 and set the input level using the slider control or by entering a number (-70 to +6 dB) in the window.
- **Input Ch 3** – assign Input Channel 3 to the desired output bus or tie to Channel 4 and set the input level using the slider control or by entering a number (-70 to +6 dB) in the window.
- **Input Ch 4** – assign Input Channel 4 to the desired output bus or tie to Channel 3 and set the input level using the slider control or by entering a number (-70 to +6 dB) in the window.

Select the **Default** button to return to the default value. Select the **Invert** button to produce a 180 degree phase reversal.

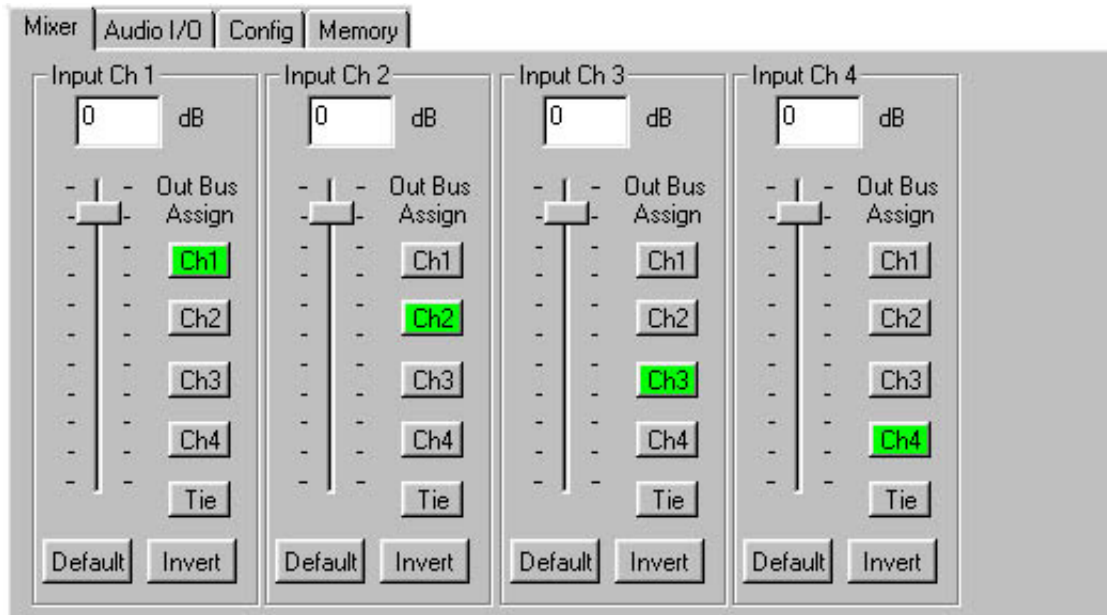

The **Audio I/O** menu shown below shows the status of the **AES A** and **AES B** audio inputs and allows you to set the source of the audio and the levels of the input and output analog audio from the 5610, 5611 or 5612 options.

- **In 1/2 Sel** – selects the input audio source from either the **AES A** (input BNC), **Anlg 1/2** or **Anlg 3/4** (5610 or 5612 Analog Audio option inputs).
- **In 3/4 Sel** – selects the input audio source from either the **AES B** (input BNC), **Anlg 1/2** or **Anlg 3/4** (5610 or 5612 Analog Audio option inputs).
- **Anlg 1 Lvl** – set the audio level (-10 dB, -6dB, -4 dB, 0 dB, +4 dB or +8 dB) for analog audio input 1 (5610 or 5612 option) or analog output 1 (5611 option).
- **Anlg 2 Lvl** – set the audio level for analog audio input 2 (5610 or 5612 option) or analog output 2 (5611 option).
- **Anlg 3 Lvl** – set the audio level for the analog audio input 3 (5610 option) or analog output 3 (5611 option) or analog output 1 (5612 option).
- **Anlg 4 Lvl** – set the audio level for the analog audio input 4 (5610 option) or analog output 4 (5611 option) or analog output 2 (5612 option).

The screenshot shows the 'Audio I/O' configuration menu with the following settings:

Control	Value
AES A Input	Locked
AES B Input	Locked
In 1/2 Sel	AES A
Anlg 1 Lvl	+4 dB
Anlg 2 Lvl	+4 dB
In 3/4 Sel	AES B
Anlg 3 Lvl	+4 dB
Anlg 4 Lvl	+4 dB

Use the **Config** menu below to set the following module parameters:

- **Aud Ref** – set the desired audio reference from either **Master Ref** or **External**.

If the 5610, 5611 or 5612 option is installed on the module, it will be reported in the **Option** status window.

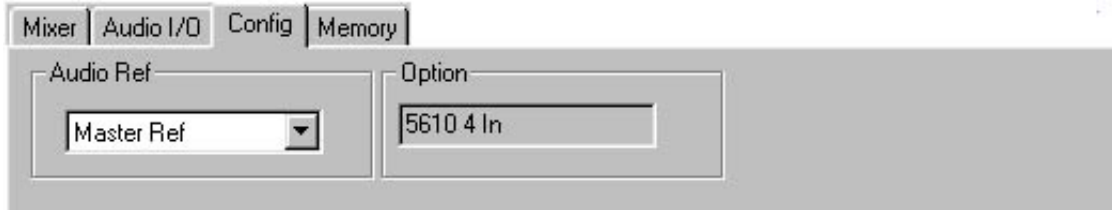

The **Memory** menu shown below allows you to store up to five different module configurations in storage registers. All parameters set in the previous menus will be saved.

To save a configuration, set all parameters as desired in the previous three menus. Select the **Save** button then one of the five register locations, **Reg 1 – Reg 5** to store your configuration.

To recall a configuration, select the desired register.



Avenue Touch Screen Remote Configuration

Avenue Touch Screen remote control menus for this module are illustrated and explained below. Refer to the 5640 Parameter Table earlier in this section for a summary of available parameters that can be set remotely through the menus illustrated. For more information on using Avenue Touch Screen, refer to the Avenue Touch Screen data pack that came with the option.

5640 Avenue Touch Screen Menus

Use the **Mixer** menu below to control the audio mixing and shuffling of the module. Each output bus assignment will be indicated by a green box.

- **Input Ch 1** – assign Input Channel 1 to the desired output bus or tie to Channel 2 and set the input level using the slider control or by entering a number (-70 to +6 dB) in the window.
- **Input Ch 2** – assign Input Channel 2 to the desired output bus or tie to Channel 1 and set the input level using the slider control or by entering a number (-70 to +6 dB) in the window.
- **Input Ch 3** – assign Input Channel 3 to the desired output bus or tie to Channel 4 and set the input level using the slider control or by entering a number (-70 to +6 dB) in the window.
- **Input Ch 4** – assign Input Channel 4 to the desired output bus or tie to Channel 3 and set the input level using the slider control or by entering a number (-70 to +6 dB) in the window.

Select the **Default** button to return to the default value. Select the **Invert** button to produce a 180 degree phase reversal.

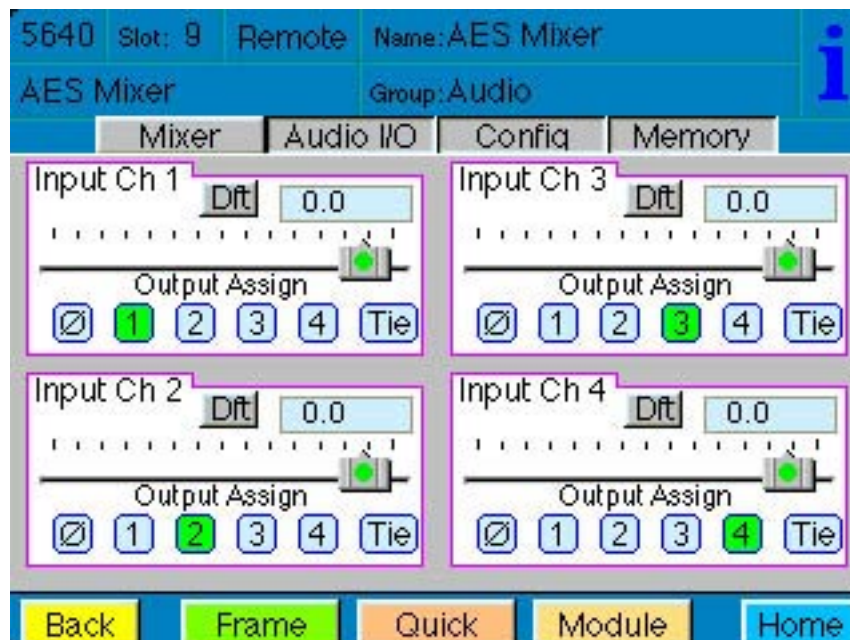

The **Audio I/O** menu shown below shows the status of the **AES A** and **AES B** audio inputs and allows you to set the source of the audio and the levels of the input and output analog audio from the 5610, 5611 or 5612 options.

- **In 1/2 Sel** – selects the input audio source from either the **AES A** (input BNC), **Anlg 1/2** or **Anlg 3/4** (5610 or 5612 Analog Audio option inputs).
- **In 3/4 Sel** – selects the input audio source from either the **AES B** (input BNC), **Anlg 1/2** or **Anlg 3/4** (5610 or 5612 Analog Audio option inputs).
- **Anlg 1 Lvl** – set the audio level (-10 dB, -6dB, -4 dB, 0 dB, +4 dB or +8 dB) for analog audio input 1 (5610 or 5612 option) or analog output 1 (5611 option).
- **Anlg 2 Lvl** – set the audio level for analog audio input 2 (5610 or 5612 option) or analog output 2 (5611 option).
- **Anlg 3 Lvl** – set the audio level for the analog audio input 3 (5610 option) or analog output 3 (5611 option) or analog output 1 (5612 option).
- **Anlg 4 Lvl** – set the audio level for the analog audio input 4 (5610 option) or analog output 4 (5611 option) or analog output 2 (5612 option).

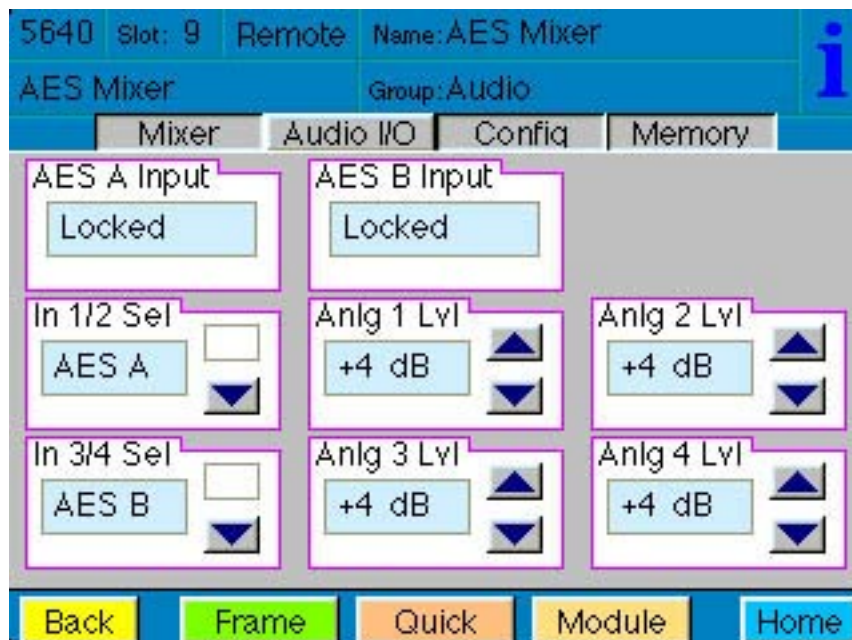

Use the **Config** menu below to set the following module parameters:

- **Aud Ref** – set the desired audio reference from either **Master Ref** or **External**.

If the 5610, 5611 or 5612 option is installed on the module, it will be reported in the **Option** status window.

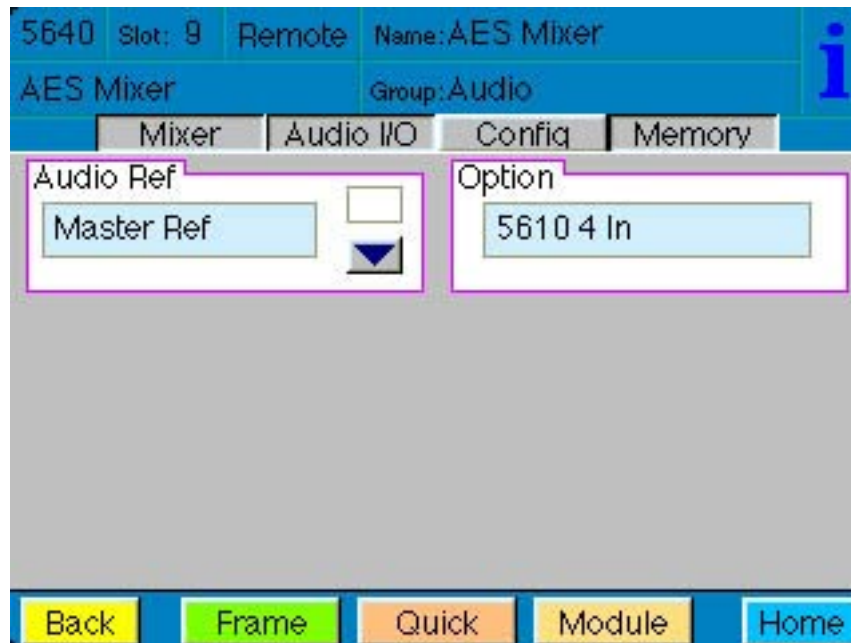

The **Memory** menu shown below allows you to store up to five different module configurations in storage registers. All parameters set in the previous menus will be saved.

To save a configuration, set all parameters as desired in the previous three menus. Select the **Save** button then one of the five register locations, **Reg 1 – Reg 5** to store your configuration.

To recall a configuration, select the desired register.

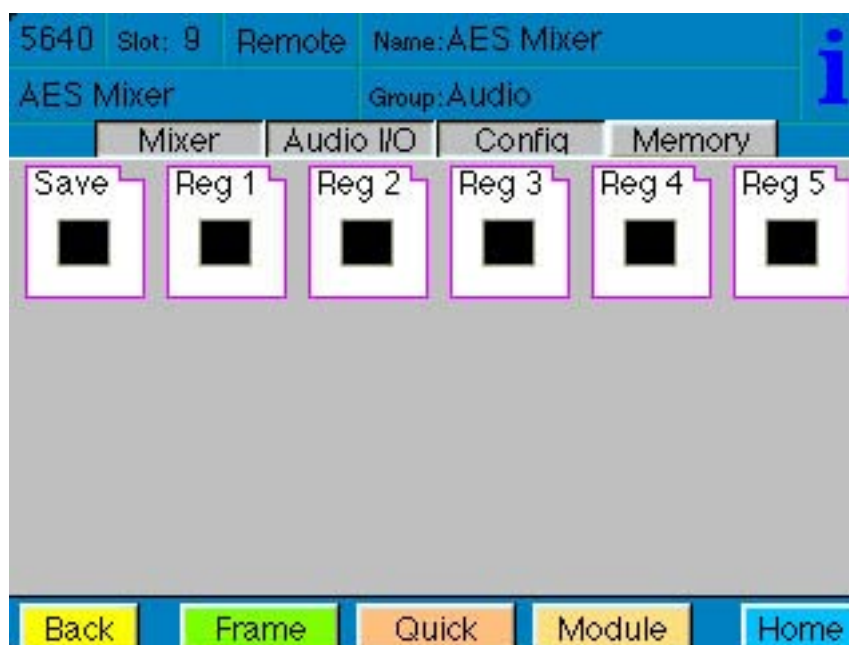

TROUBLESHOOTING

To aid in troubleshooting, the LED indicators can be easily monitored from the front panel of this module to show module status.

If using the **Remote** mode, status items can also be monitored using the Avenue Touch Screen Control Panel or PC Application:

Refer to the overall troubleshooting tips given below for the module:

No status lights are lit on front panel:

- Check that frame power is present (green LED{s} on frame power supplies).
- Check that module is firmly seated in frame. Try removing it and plugging it in again.

Can't control module:

- Check status of CPU **Run** green LED. Should be blinking slowly and in unison with other modules if System module is present. If not, try removing it and plugging it in again.
- System module may not be working properly if installed.

No signal out of module:

- Check status of **AES A** and **AES B** green LED. Should be lit. If not, check the input signal for presence and quality.
- Check cabling to input of module.

You may also refer to the technical support section of the Ensemble or Graham-Patten web sites for the latest information on your equipment at the URLs below:

<http://www.ensembledesigns.com/support>

<http://www.grahampatten.com>

SOFTWARE UPDATING

Software upgrades for each module can be downloaded remotely if the optional System Control module is installed. These can be downloaded onto your PC and then Avenue PC will distribute the update to the individual module. (Refer to the Avenue PC documentation for more information) Periodically updates will be posted on our web site. If you do not have the required System Control Module and Avenue PC, modules can be sent back to the factory for software upgrades.

WARRANTY AND FACTORY SERVICE

Warranty

This Module is covered by a five year limited warranty, as stated in the main Preface of this manual. If you require service (under warranty or not), please contact Ensemble Designs or Graham-Patten Systems and ask for customer service before you return the unit. This will allow the service technician to provide any other suggestions for identifying the problem and recommend possible solutions.

Factory Service

If you return equipment for repair, please get a Return Material Authorization Number (RMA) from the factory first.

Ship the product and a written description of the problem to:

Ensemble Designs, Inc.

Attention: Customer Service RMA #####

870 Gold Flat Rd.

Nevada City, CA. 95959 USA

(530) 478-1830

Fax: (530) 478-1832

service@endes.com

<http://www.ensembledesigns.com>

Be sure to put your RMA number on the outside of the box.

OR

Graham-Patten Systems, Inc.

13366 Grass Valley Avenue

Grass Valley, CA 95945

(800) 422-6662 or (530) 273-8412

Fax: (530) 273-7458

service@gpsys.com

<http://www.grahampatten.com>

SPECIFICATIONS

5640 Mix

Audio Input Signal

Number: 2, AES A and AES B
Channels: 4 total
Signal Type: AES
Impedance: 75 ohm

Audio Output Signal

Number: 2, AES A and AES B
Channels: 4 total
Signal Type: AES
Impedance: 75 ohm

Model 5610 Analog Input Option

Analog Inputs: 4, Balanced Pair
Processing: 24 bits
Analog Input Z: >15k Ω balanced, transformerless
Max Output Level: +24 dBu (bridging load), +22 dBu (600 Ω load)

Model 5611 Analog Output Option

Analog Outputs: 4, Balanced Pair
Processing: 24 bits
Analog Input Z: 30k Ω balanced, transformerless
Max Output Level: +24 dBu (bridging load), +22 dBu (600 Ω load)

Model 5612 Analog Input and Output Option

Analog Inputs: 2, Balanced Pair
Processing: 24 bits
Analog Input Z: >15k Ω balanced, transformerless
CMRR: >60 dB, 20Hz – 10kHz

Analog Outputs: 2, Balanced Pair
Processing: 24 bits
Analog Input Z: 30k Ω balanced, transformerless
Max Output Level: +24 dBu (bridging load), +22 dBu (600 Ω load)

General Specification Common to All Analog Options

Analog Reference
Level: -10 dBu to +8 dBu for -20 dBFS output
Frequency Response: +0/-0.1 dB, 20 Hz – 20k Hz
Crosstalk: <84 dB, 20 Hz – 20k Hz
Dynamic Range: >=95 dB

5600 General Specifications

Power Consumption:	< 5.0 watts
Fusing:	1.5 PTC resettable fuse
Temperature Range:	0 to 40 degrees C ambient (all specs met)
Relative Humidity:	0 to 95% noncondensing
Altitude:	0 to 10,000 ft

Due to ongoing product development, all specifications subject to change.