

AVENUE

Avenue™ signal integration system

Model 7910 HD Upconverter And Cross Converter Data Pack

ENSEMBLE

D E S I G N S

Revision 2.4 SW v2.3.3

This data pack provides detailed installation, configuration and operation information for the **7910 HD Upconverter and Cross Converter** module as part of the Avenue Signal Integration System.

The module information in this data pack is organized into the following sections:

- Module Overview
- Applications
- Installation
- Cabling
- Module Configuration and Control
 - Front Panel Controls and Indicators
 - Avenue PC Remote Control
 - Avenue Touch Screen Remote Control
- Troubleshooting
- Software Updating
- Warranty and Factory Service
- Specifications

MODULE OVERVIEW

The 7910 module is an SD to HD Upconverter with a standard definition SDI input and four HD SDI outputs. The 7910 also provides Cross Conversion when an HD signal is connection to its SD In BNC. The module is excellent for on-air use or in an HD island, in a signal ingest installation, or in a production application. Refer to the functional block diagram for the module on the next page.

Sophisticated Adaptive Noise Reduction ensures delivery of a pristine output that is excellent for use in broadcast. Picture Detail Enhancement is used to recover information that has been lost due to poor frequency response upstream. Different aspect ratio conversion choices are available for selection on the HD output.

Input standard and frame rate are auto-detected. The 7910 automatically adjusts from SD to HD color space and gamma. The built-in Proc Amp provides adjustment of signal parameters with controls for Video Gain, Chroma, Pedestal, and Hue.

HD closed captioning is carried in data packets in the vertical interval ancillary data space. The 7910 properly translates between traditional SD captioning (line 21 or 23) and HD caption data so that closed captioning content is converted transparently between video standards and formats.

The converted output is timeable with respect to the reference input. When converting to film rate (1080sF/23.98) formats, 3:2 pulldown cadence is automatically detected and backed out when present in the input. 3:2 detection can be enabled and disabled.

One of three types of audio submodules can be installed on the main circuit board:

- The 8415 is a 8 channel audio submodule with AES I/O that provides management of embedded audio in the processing path, or supports audio embedding/disembedding alongside the video processing elements. Embedded audio is safely bypassed around the video frame store with lip sync preserved. Level adjustments and channel shuffling are accessed through the built-in audio mixer. All audio processing is performed at full 24 bit resolution by a digital signal processor (DSP).
- The 7610 audio submodule provides carriage of up to eight channels of embedded audio through the format conversion process. Embedded audio in the input signal is delayed to match the video delay and preserve lip sync. The delayed content is reinserted in the video output. No level adjustment or channel swapping is provided.
- The 7615 audio submodule also provides processing for signals with eight channels of embedded audio. It offers the same processing and AES I/O as the 8415 plus the ability to decode Dolby-E signals.

The 7910 can be configured locally or controlled and configured remotely with Avenue Touch Screens, Express Panels, or Avenue PC Software. Alarm generators, configurable user levels, module lock out, and customizable menus are just some of the tools included in the Avenue Control system.

The on-board CPU can monitor and report module ID information (slot location, software version and board revision), power status, and ancillary data status to the optional frame System Control module. This information can be accessed by the user or set to register an alarm if desired using the remote control options available.

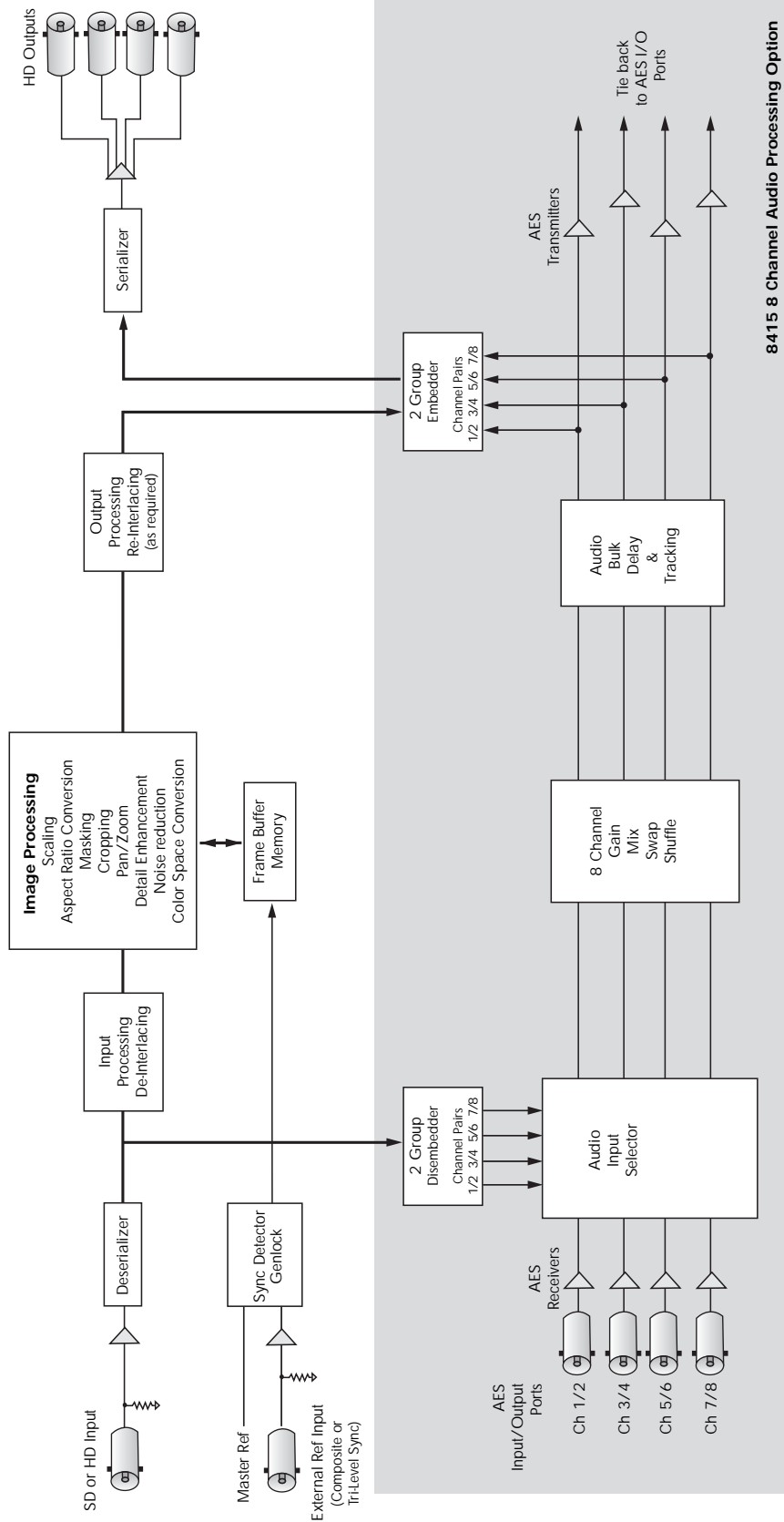

7910 HD Upconverter And Cross Converter Functional Block Diagram, Landscape View

Model 7910 HD Upconverter And Cross Converter

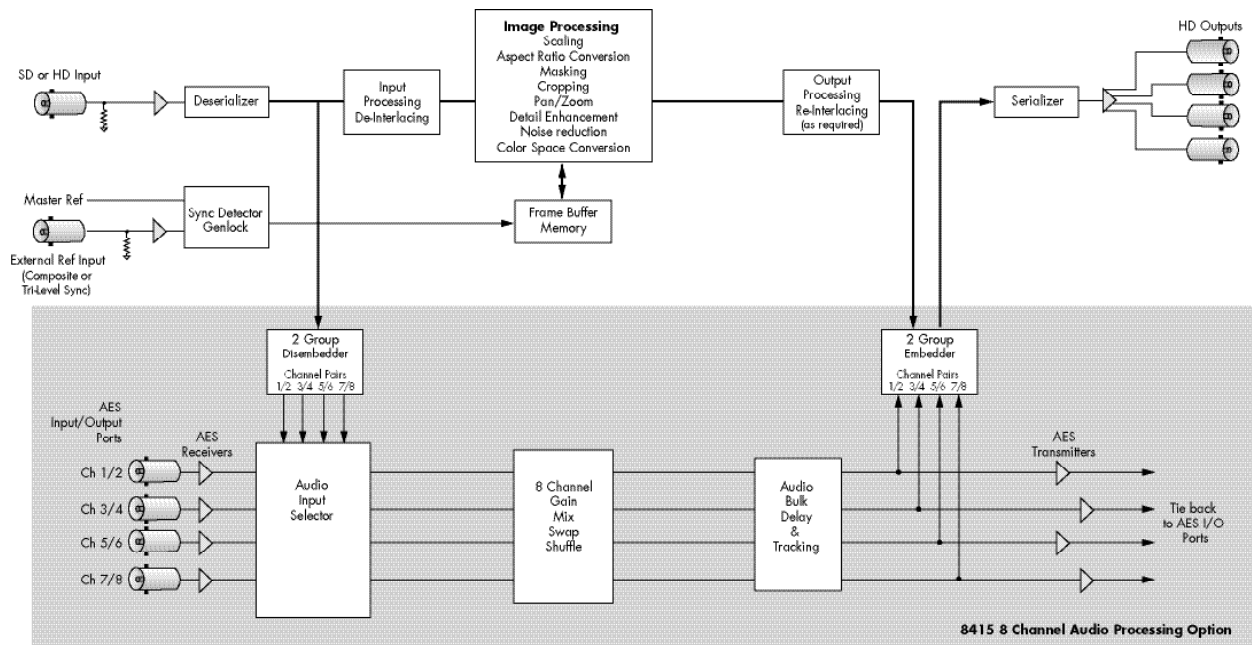

7910 HD Upconverter And Cross Converter Functional Block Diagram, Portrait View

(This page is intentionally blank.)

Power is derived from the ± 12 volt frame power. It is regulated to the required +5 volts for the module by an on-board regulator. The module is fused with a resettable fuse device. If the fuse opens due to an overcurrent condition, the module will lose power. After pulling the module, the fuse will reset automatically requiring no replacement fuse.

Modules at software version 2.2.0 or later support SNMP (Simple Network Management Protocol) monitoring. For each applicable signal processing module, module, signal, and reference status are reported. For complete details on using SNMP monitoring, refer to the **Avenue System Overview** in the manual that accompanies each frame.

APPLICATIONS

SD Upconversion

The 7910 module can be utilized to upconvert SD video from many different source types, or cross convert HD video into all popular variations of 1080 and 720.

As shown in the example below, the SD ingest signal from a satellite is fed to a 7910 module where it is upconverted to feed an HD Master Control Switcher. The other three outputs can be sent to other HD destinations.

Along with accurate upconversion, the module provides sophisticated adaptive noise reduction for noisy input signals for use in broadcast applications. Timing to a house reference is available on the module, along with many other controls features for ensuring a clean, stable signal.

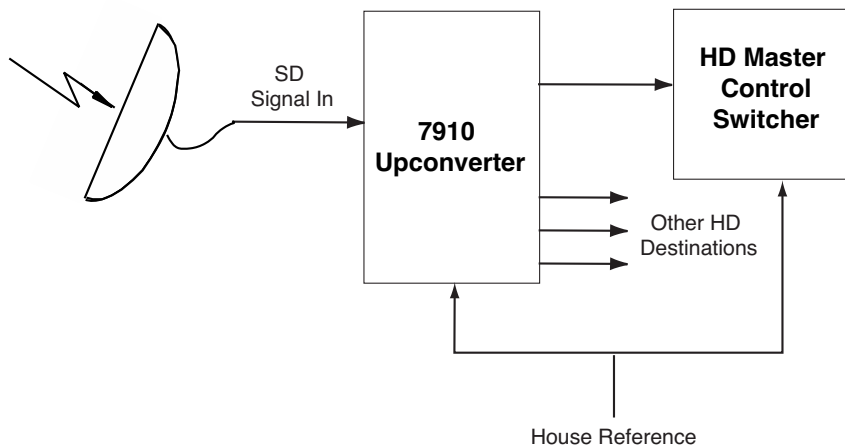

7910 SD Upconverter Application

APPLICATIONS

HD Cross Conversion

The 7910 module can be utilized to cross convert between HD 1.5 Gb/s formats, processing all popular variations of 1080 and 720, making it simple for facilities to ingest any type of HD signal. As shown in the example below, the 1080i input from an HD network feed is fed to the 7910 where the format is converted to 720p as required for input to an HD router.

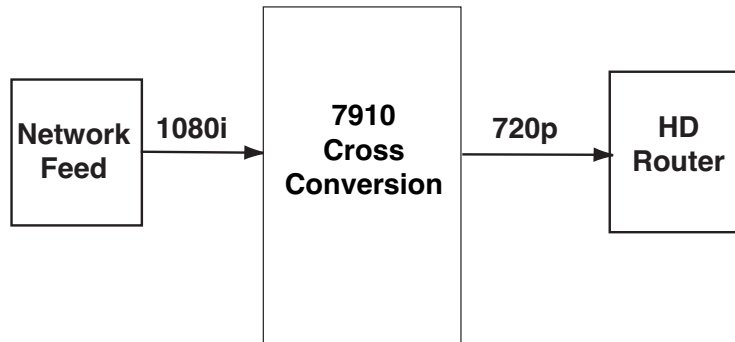

7910 HD Cross Converter Application

Auto Sensing Upconversion And Cross Conversion

The 7910 can either upconvert or cross convert as needed. As shown below, the output of the 7910 has been set to 1080i. In this setup, the video server could, for example, play 720 or 1080 program material then play SD commercials. The 7910 will accept SD or HD inputs and automatically convert to 1080i..

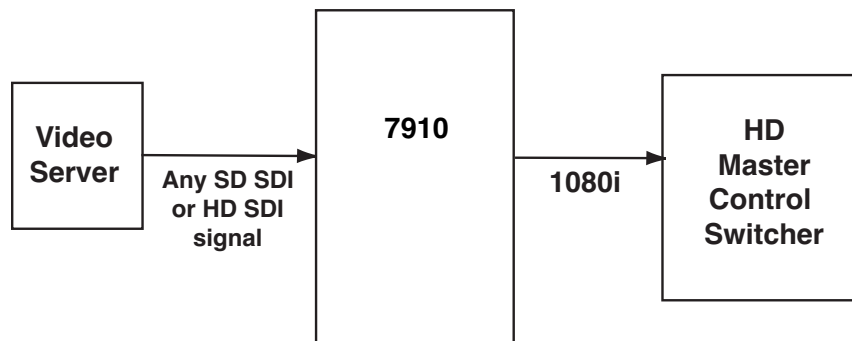

Auto Sensing Upconversion And Cross Conversion Application

INSTALLATION

Audio Submodule Installation

The optional audio submodules install on the component side of the 7910 module circuit board. If a submodule is ordered with the 7910, that module will come pre-installed.

To install an audio submodule manually, locate the three connectors on the left side of the circuit board as shown below and line the connectors up, checking their alignment. Press carefully into place to seat the submodule.

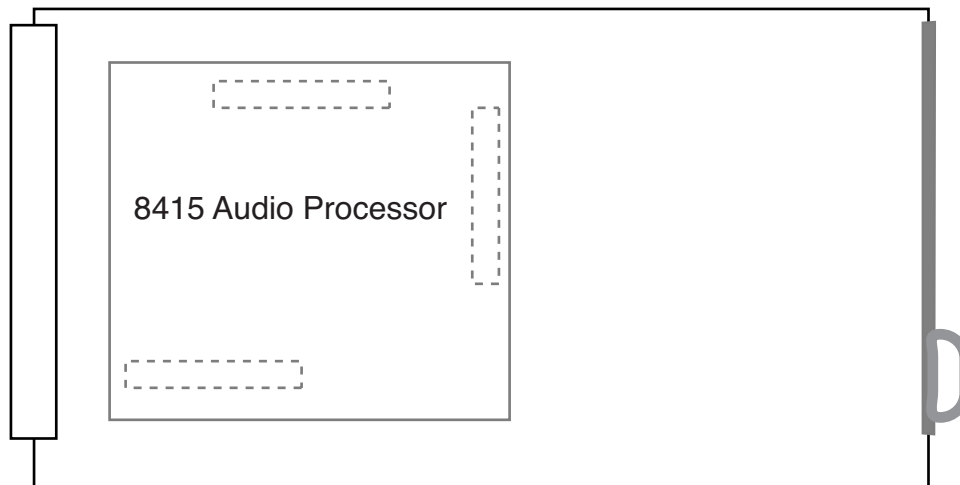

Audio Submodule Installation

7910 Video Processing Module

Plug the 7910 module into any one of the slots in the 1 RU or 3 RU frame and install the plastic overlay provided onto the corresponding group of rear BNC connectors associated with the module location.

Note that the plastic overlay has an optional adhesive backing for securing it to the frame. Use of the adhesive backing is only necessary if you would like the location to be permanent and is not recommended if you need to change module locations. This module may be hot-swapped (inserted or removed) without powering down or disturbing performance of the other modules in the system.

CABLING

Refer to the 3 RU and 1 RU backplane diagrams of the module below for cabling instructions. Unless stated otherwise, the 1 RU cabling explanations are identical to those given in the 3 RU diagram.

3 RU Backplane

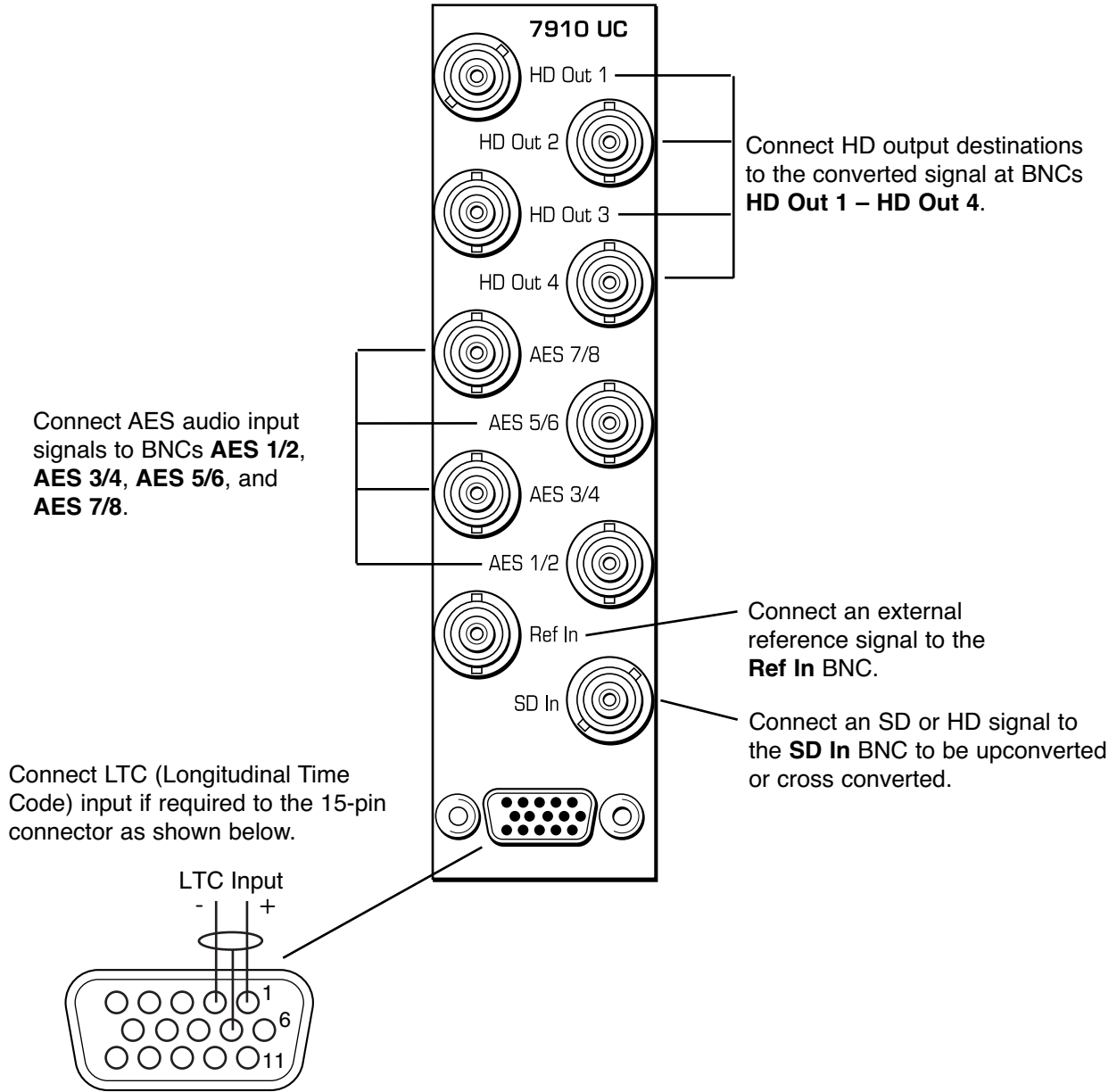

1 RU Backplane

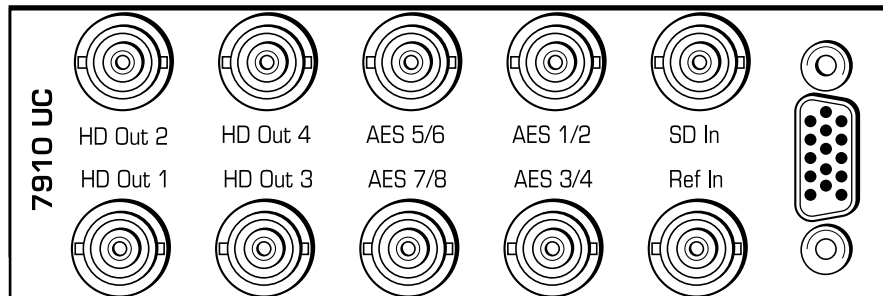

MODULE CONFIGURATION AND CONTROL

The configuration parameters for each Avenue module must be selected after installation. This can be done remotely using one of the Avenue remote control options, or locally using the module front panel controls. Each module has a **Remote/Local** switch on the front edge of the circuit board which must first be set to the desired control mode.

Configuration parameter choices for the module differ between **Remote** and **Local** modes. In **Remote** mode, choices are made through software and allow more selections. The **7910 Parameter Table** on page 9 summarizes and compares the various configuration parameters that can be set remotely or locally and the default/factory settings. It also shows the default User Levels for each control. These levels can be changed using the Avenue PC application

If you are not using a remote control option, the module parameters must be configured from the front panel switches. Parameters that have no front panel control will be set to a default value. The **Local** switches are illustrated in the **Front Panel Controls and Indicators** section on page 11. The **Local** switches are inactive when the **Remote/Local** switch is in the **Remote** position.

In **Remote** mode, Avenue module parameters can be configured and controlled from one of the remote control options, the Avenue Touch Screen, Avenue Express Control Panel, or the Avenue PC Application. Once the module parameters have been set remotely, the information is stored on the module's CPU. This allows the module to be moved to a different slot in the frame at your discretion without losing the stored information.

To set parameters remotely using the Avenue PC option, refer to the **Avenue PC Remote Configuration** section on page 12.

To set parameters remotely using the Avenue Touch Screen option, refer to the **Avenue Touch Screen Remote Configuration** section on page 23.

Express Panel operation is described in the data pack that accompanies the control panel option.

CONTROL	LOCAL	REMOTE	FACTORY DEFAULT	DEFAULT USER LEVEL
Reference Source	Ext Ref	Ext Ref Master Ref Video In Ref	Ext Ref	Level 1
Mode	Mode Switch1: Ana or Proc Mode Switch 2: Box or Crop	Anamorphic Pillar Box Crop Sides Manual	Anamorphic	Level 1
Up	Anamorphic	Anamorphic Pillar Box Crop Manual	Anamorphic	Level 1
HD Cross	Anamorphic	Anamorphic Manual	Anamorphic	Level 1
Output Standard	Format Switch1: 1080i or 720p If 1080i: Format Switch2: 1080i or sF	720p/50 720p/59.94 1080i/50 1080i/59.94 1080i60 1080i/25 1080i/23.98 1080isF/25 1080isF/23.98 1080isF/24	1080i/59.94	Level 1
Width (Manual)	100%	+/- 100%	100%	Admin
Height (Manual)	100%	+/- 100%	100%	Admin
Hor Position (Manual)	0%	+/- 100%	0%	Admin
Ver Position (Manual)	0%	+/- 100%	0%	Admin
Noise Reduce	Off	Off Low Medium High	Off	Admin
Detail	Off	Off Low Medium High	Off	Admin
3:2 Detect	Off	Off On	Off	Level 2

7910 Parameter Table (Continued)

CONTROL	LOCAL	REMOTE	FACTORY DEFAULT	DEFAULT USER LEVEL
Gain	100%	0 – 150%	100%	Admin
Chroma	100%	0 – 150%	100%	Admin
Pedestal	0 IRE	+/- 30 IRE	0 IRE	Admin
Hue	0 IRE	+/- 180 degrees	0 degrees	Admin
Vert Blanking	Wide	Wide Narrow	Wide	Level 1
Test Pattern	Off	Off Bars Black	Off	Level 1
Hor Timing	0 clocks	+/- 2000 clocks	0 clocks	Admin
Ver Timing	0 lines	+/- 1000 lines	0 lines	Admin
Cpst Out Setup	Off	Off On	Off	Level 2
Ch 1-8 In (level)	0 dB	-70 to +12 dB	0 dB	Level 1
Ch 1-8 Output Bus	Ch 1 – Output 1 Ch 2 – Output 2 Ch 3 – Output 3 Ch 4 – Output 4 Ch 5 – Output 5 Ch 6 – Output 6 Ch 7 – Output 7 Ch 8 – Output 8	Output Bus 1 – 8 Tie Invert Default	Ch 1 – Output 1 Ch 2 – Output 2 Ch 3 – Output 3 Ch 4 – Output 4 Ch 5 – Output 5 Ch 6 – Output 6 Ch 7 – Output 7 Ch 8 – Output 8	Level 1
Auto Track	On	Off On	On	Level 1
Bulk Delay	0 msec	0 – 1000 msec	0 msec	Level 1
1/2 Input 3/4 Input 5/6 Input 7/8 Input	Audio Switch 1: AES or Embed	AES 1/2 AES 3/4 AES 5/6 AES 7/8 SDI 1/2 SDI 3/4 SDI 5/6 SDI 7/8	AES 1/2 AES 3/4 AES 5/6 AES 7/8	Level 1

7910 Parameter Table (Continued)

CONTROL	LOCAL	REMOTE	FACTORY DEFAULT	DEFAULT USER LEVEL
1/2, 3/4, 5/6, 7/8 Demux Group	Group 1	Group 1 Group 2 Group 3 Group 4	Group 1	Level 1
1/2, 3/4, 5/6, 7/8 Mode	Auto	Audio Data Auto	Auto	Level 1
Audio Embed A and B	A Replace All B Replace All	Off Replace Cascade Replace All	A Replace All B Replace All	Level 1
Mux Group A and B	Group 1	Group 1 Group 2 Group 3 Group 4	Group 1	Level 1
Dig Ref Level	-20 dBFS	-20 dBFS -18 dBFS	-20 dBFS	Level 1
CC Input Line	Line 21	Lines 19 – 23	Line 21	Admin
Captions Out	Off	Off On	Off	Level 1
Timecode Source	LTC	LTC VITC Line 14 VITC Line 15 VITC Line 16 VITC Line 17 VITC Line 18 VITC Line 19 VITC Line 20	LTC	Level 1
Timecode Output	Off	Off LTC VITC LTC & VITC	Off	Level 1

Front Panel Controls and Indicators

The front edge indicators and switch settings are shown in the diagram below:

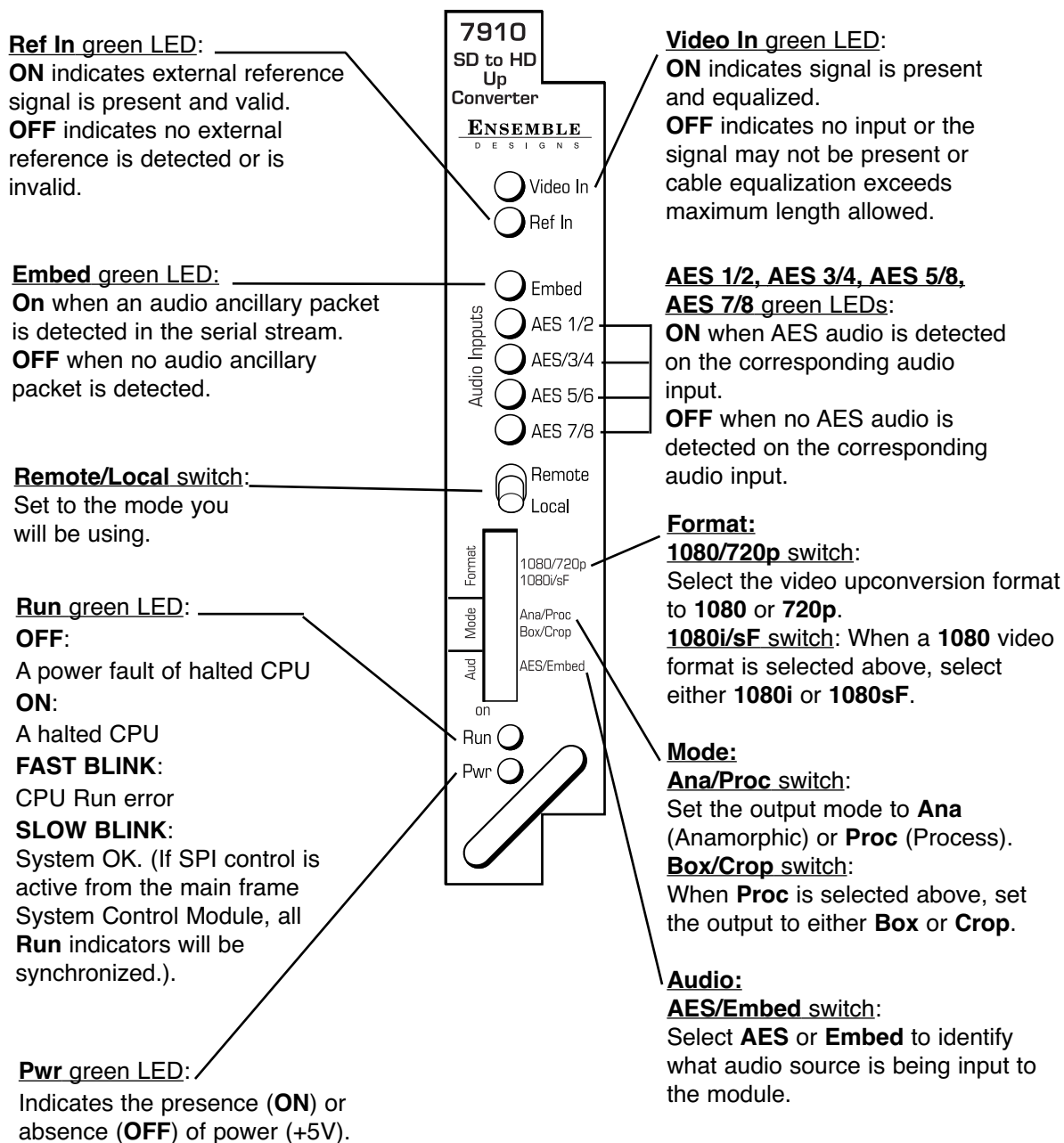

Avenue PC Remote Configuration

The Avenue PC remote control menus for this module are illustrated and explained below. Refer to the **7910 Parameter Table** for a summary of available parameters that can be set remotely through the menus illustrated. The **Configuration Summary** gives tips and general background information on setting the parameters. For more information on using Avenue PC, refer to the Avenue PC Control Application Software data pack.

Parameter fields that are grayed out can indicate one of the following conditions:

- An option is not installed.
- The function is not active.
- The module is locked.
- The User Level set with Avenue PC is not accessible from the current User Level.

7910 AVENUE PC MENUS

The **Vid In** menu shown below allows you to configure the following:

- **Ref Source** – use this control to set the reference input source.

Status reporting is provided for the following conditions:

- **Input** – indicates signal is present and equalized.
- **WSS/AFD In** – the Wide Screen Signal/Active Format Descriptions In indicator displays the format of the input signal connected to the Video In BNC as one of the following: **None**, **Full Frame**, **Letter 14:9**, **Letter 14:9T**, **Letter 16:9**, **Letter 16:9T**, **Anamorphic**, **Pillar 4x3**, **Pillar 14x9**, **Unknown WSS**, **Unknown AFD**.
- **Reference** – reports the status of the reference input as either **No Reference**, **Ref 525 Lock**, **Ref 625 Lock**, or **Ref TLS Lock**.

Aud Delay	Aud In A	Aud In B	Aud Out	MetaData	Memory		
Vid In	Mode	Manual	Config	Proc	Vid Out	Aud Mix A	Aud Mix B
Input		WSS / AFD In					
No Input		None					
Ref Source		Reference					
Master Ref		No Reference					

The **Mode** menu shown below allows you to configure the following:

- **Mode** – use this control to set the aspect ratio for the upconverted HD video output. When **Manual** is selected, use the **Manual** menu given next.
- **Output Standard** – use this control to set the desired output standard for upconversion.
- **Up** – use this control to set the desired output aspect ratio when upconverting the input signal (**Anamorphic, Letter 16:9, Letter 14:9, Letter 13:9, Pillar, Crop Sides 75%, Crop Sides 84%, Crop Top/Bot, WSS/AFD Auto 16x9, WSS/AFD Auto 14x9, WSS/AFD Auto 4x3, Manual**). When **Manual** is selected, use the **Manual** menu to set the aspect ratio.
- **HD Cross** – use this control to set the desired output aspect ratio when cross converting from one type of HD signal to another (**Anamorphic, Letter 16:9, Letter 14:9, Letter 13:9, Pillar, Crop Sides 75%, Crop Sides 84%, Crop Top/Bot, WSS/AFD Auto 16x9, WSS/AFD Auto 14x9, WSS/AFD Auto 4x3, Manual**). When **Manual** is selected, use the **Manual** menu to set the aspect ratio.

Aud Delay	Aud In A	Aud In B	Aud Out	MetaData	Memory		
Vid In	Mode	Manual	Config	Proc	Vid Out	Aud Mix A	Aud Mix B

Mode	Output Standard
Up Convert	1080i/59.94
Up	HD Cross
Anamorphic	Anamorphic

When **Manual** is selected in the **Mode** menu above, the **Manual** menu shown below will become active. Set the aspect ratio of the upconverted HD output as desired with the following controls:

- **Width** – set the aspect ratio width.
- **Height** – set the aspect ratio height.
- **Hor Position** – set the horizontal position of the output.
- **Ver Position** – set the vertical position of the output.

Use the **Default** button in each control to return to the default value.

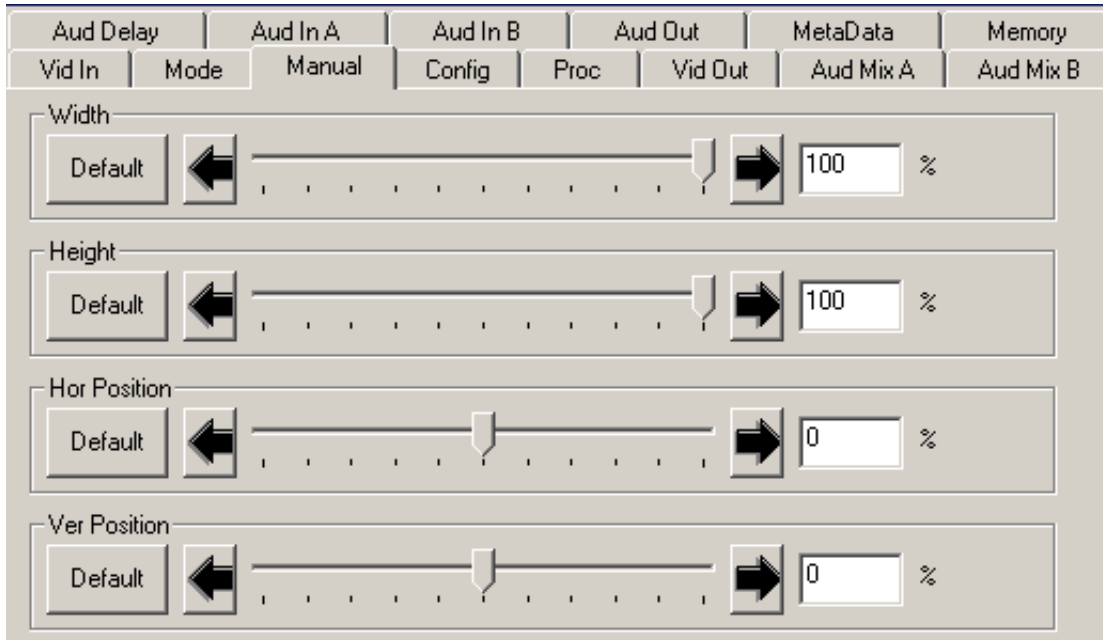

Use the **Config** menu below to enable the following controls:

- **Noise Reduce** – adjusts the amount of noise reduction on the output signal from **Off, Low, Medium, or High**. The typical setting for this parameter is **Off** or **Low**.
- **Detail** – adjusts the amount of picture detail enhancement on the output from **Low, Medium, or High**. The typical setting for this parameter is **Off** or **Low**.
- **3:2 Detect** – turns the control to detect video that has been converted from film, **On** or **Off**. Use this only for film applications. The typical setting for this parameter is **Off**.

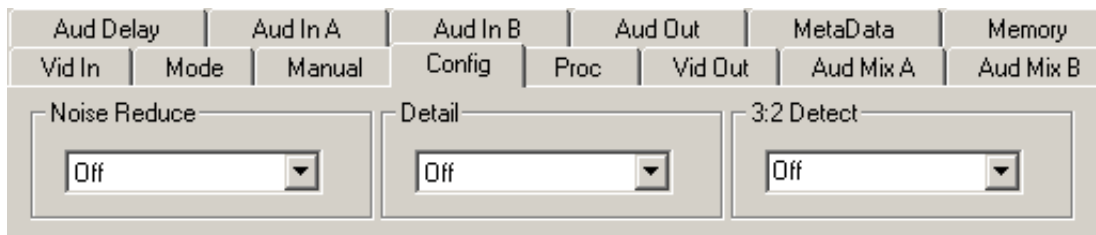

The **Proc** menu shown below allows you to adjust the following video processing parameters for the signal:

- **Gain** – adjust the percentage of overall gain (luminance and chrominance).
- **Chroma** – adjust the percentage of chroma amplitude.
- **Pedestal** – adjust the pedestal (black) level of the signal in IRE.
- **Hue** – adjust the hue of the signal ± 180 degrees.

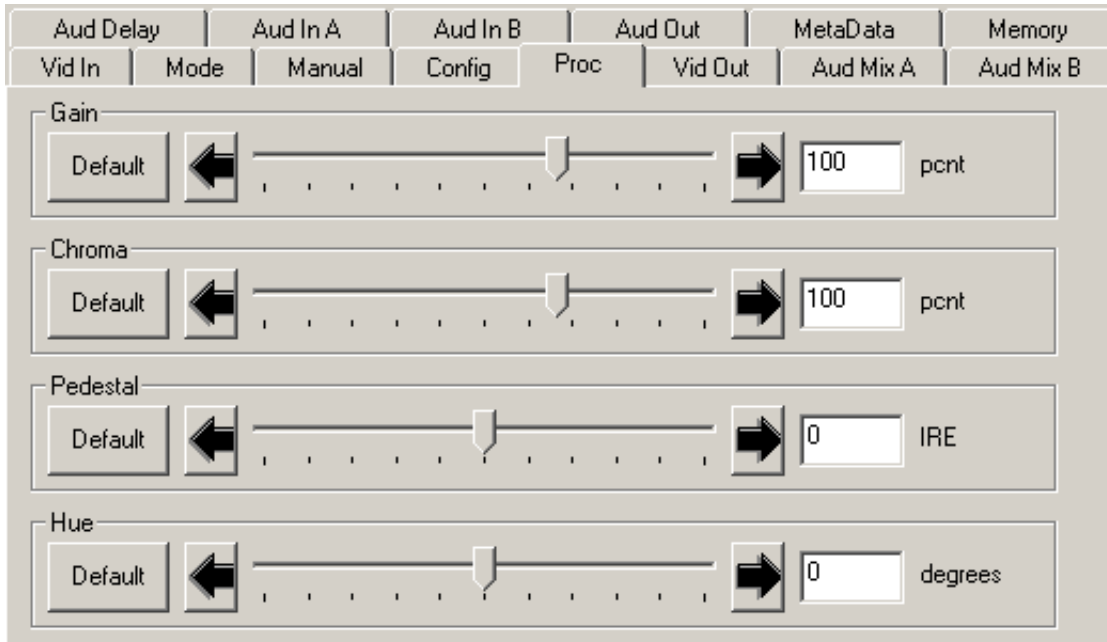

Use the **Vid Out** menu shown below to adjust the following parameters:

- **Test Pattern** – select a test pattern to be sent to the video output of the module.
- **Hor Timing** – adjust the horizontal timing of the output signal to place the leading edge of sync coincident with other sources.
- **Vertical Timing** – set the vertical timing to a typical setting of 0 lines.

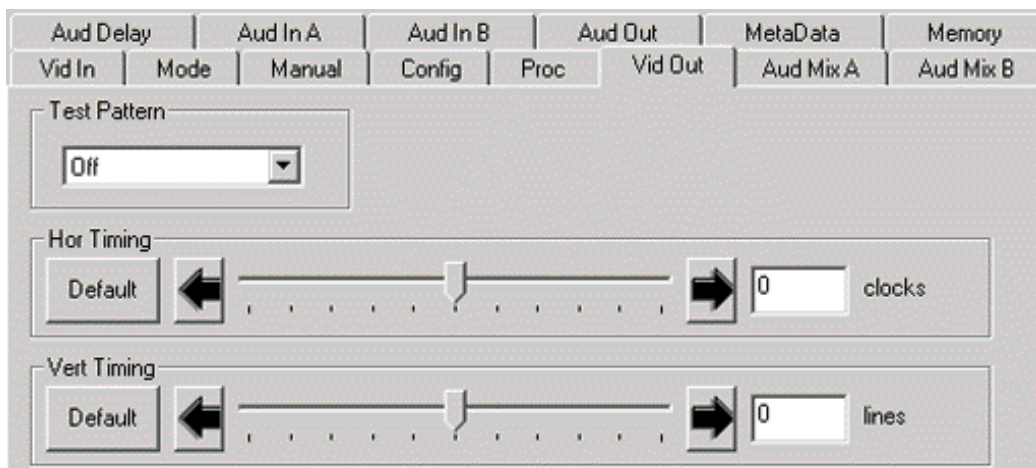

When an 8415 Audio Processor submodule is installed, use the **Aud Mix A** and **B** menus control the audio mixing and shuffling of the module. Output bus assignments are indicated in green.

For Channels 1 –4, use the **Audio Mix A** menu to set the following:

- **Input Ch 1** – assign Input Channel 1 to the desired output bus or tie to Channel 2. Set the input level using the slider control or by entering a number in the window and pressing the **Enter** key on your PC.
- **Input Ch 2** – assign Input Channel 2 to the desired output bus or tie to Channel 1. Set the input level using the slider control or by entering a number in the window and pressing the **Enter** key on your PC.
- **Input Ch 3** – assign Input Channel 3 to the desired output bus or tie to Channel 4. Set the input level using the slider control or by entering a number in the window and pressing the **Enter** key on your PC.
- **Input Ch 4** – assign Input Channel 4 to the desired output bus or tie to Channel 3. Set the input level using the slider control or by entering a number in the window and pressing the **Enter** key on your PC.

Selecting the **Tie** button in Input Ch 1 or Input Ch 2 will tie the two controls together. Selecting the **Tie** button in Input Ch 3 or Input Ch 4 will tie the controls for these channels together.

Select the **Default** button to return to the default value.

Select the **Invert** button to invert the phase of the audio content.

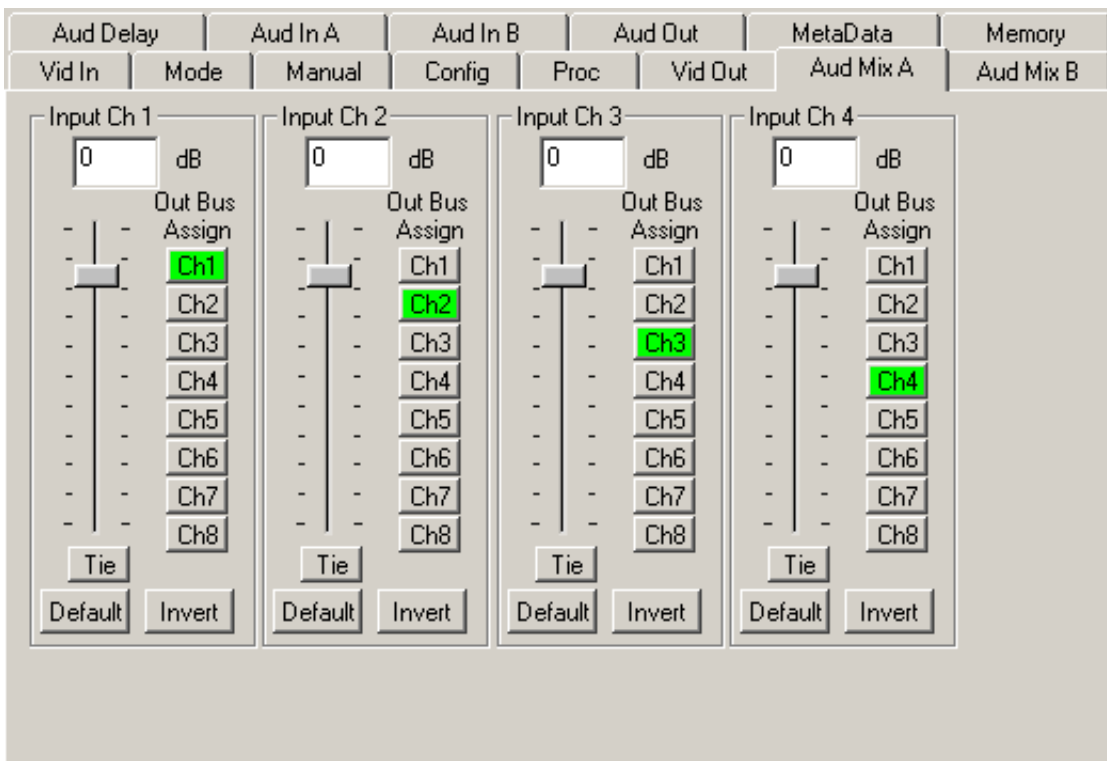

For Channels 5 – 8, use the **Audio Mix B** menu shown below to set the following:

- **Input Ch 5** – assign Input Channel 5 to the desired output bus or tie to Channel 6. Set the input level using the slider control or by entering a number in the window and pressing the **Enter** key on your PC.
- **Input Ch 6** – assign Input Channel 6 to the desired output bus or tie to Channel 5. Set the input level using the slider control or by entering a number in the window and pressing the **Enter** key on your PC.
- **Input Ch 7** – assign Input Channel 7 to the desired output bus or tie to Channel 8. Set the input level using the slider control or by entering a number in the window and pressing the **Enter** key on your PC.
- **Input Ch 8** – assign Input Channel 8 to the desired output bus or tie to Channel 7. Set the input level using the slider control or by entering a number in the window and pressing the **Enter** key on your PC.

Selecting the **Tie** button in Input Ch 5 or Input Ch 6 will tie the two controls together. Selecting the **Tie** button in Input Ch 7 or Input Ch 8 will tie the controls for these channels together.

Select the **Default** button to return to the default value.

Select the **Invert** button to invert the phase of the audio content.

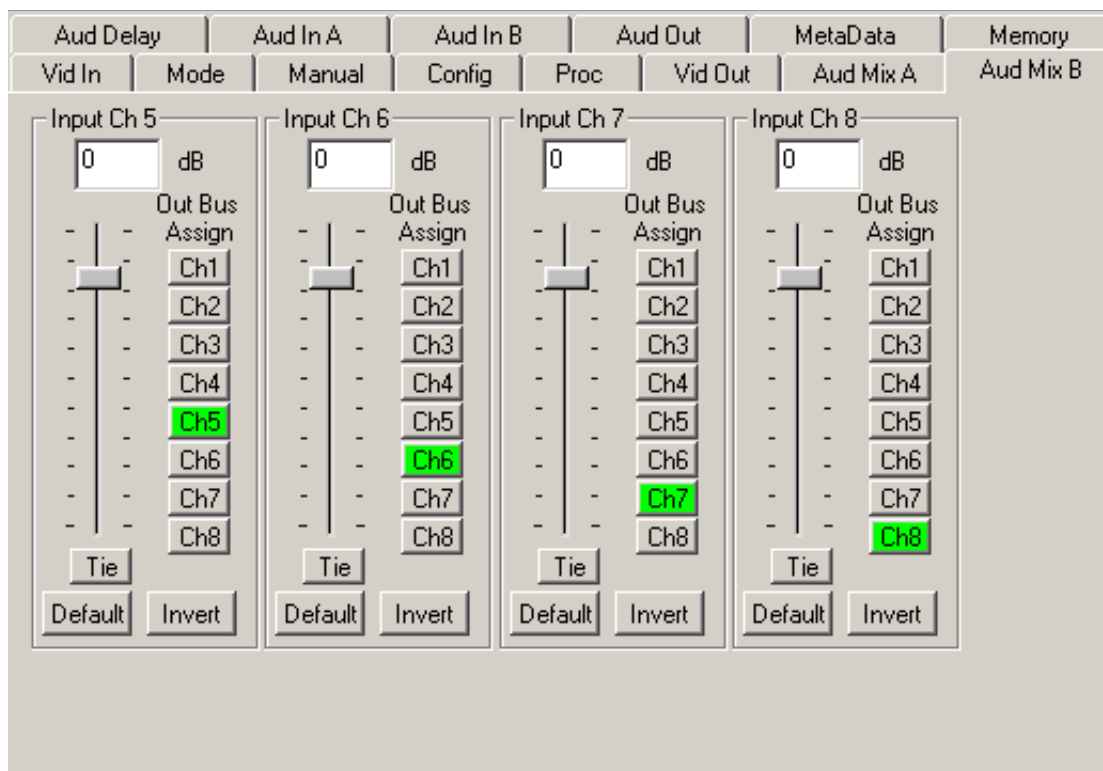

Use the **Aud Delay** menu shown below for the 8415 Audio submodule to adjust the amount of audio delay on the output:

- **Auto Track** – enable auto tracking by selecting **On** or **Off**.
- **Bulk Delay** – set the amount of bulk delay using the left and right arrows or enter a value in the **msec** field and press the **Enter** key on your PC.

The amount of total delay will be reported in msec in the **Total Delay** window.

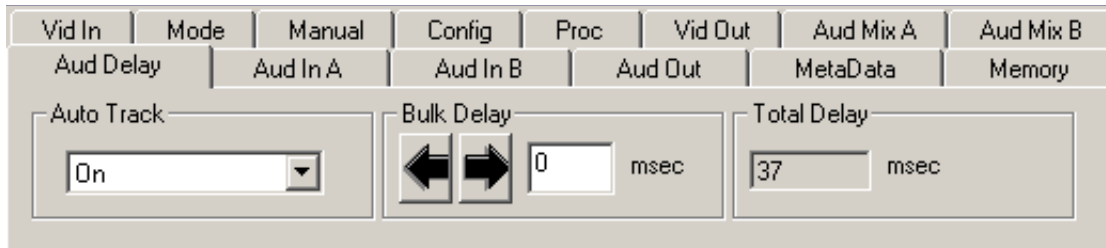

Use the **Aud In A** menu shown on the next page to adjust the following parameters:

- **1/2 Input** – select the input audio source for Input 1/2.
- **3/4 Input** – select the input audio source for Input 3/4.

When an AES input pair is selected as an input, the corresponding AES BNC on the rear of the module will become an input. If an AES input is not selected, the corresponding BNC on the rear of the module will automatically become an output. Refer to the block diagram on page 4 for an illustration of the input/output BNCs.

- **1/2 Mode** – for a Serial input with embedded audio, select the type of audio in the stream:
 - **Audio** – the embedded stream is standard audio.
 - **Data** – the embedded stream is a non-audio signal.
 - **Auto** – the module will detect the type of signal embedded in the stream, audio or data.
- **3/4 Mode** – select the type of audio in the serial stream as described above.
- **Demux Group** – select the embedded audio group to demultiplex from the selections. The status of embedded audio is shown in the **Embed In** view.

The status of the corresponding audio inputs are shown next to the control. Status is reported as one of the following:

- **No Input** – no serial digital embedded audio is detected.
- **Audio Sync** – the audio embedded in the stream is synchronous with the timing reference.
- **Data Sync** – the data embedded in the stream is synchronous with the timing reference.
- **Audio Async** – the audio embedded in the stream is non-synchronous with the timing reference.

Vid In	Mode	Manual	Config	Proc	Vid Out	Aud Mix A	Aud Mix B
Aud Delay	Aud In A	Aud In B	Aud Out	MetaData	Memory		
1/2 Input	1/2 Status	1/2 Mode					
SDI 1/2	No Input	Audio					
3/4 Input	3/4 Status	3/4 Mode					
AES 3/4	No Input	Audio					
DeMux Group	Embed In A						
Group 1	Present						

Use the **Aud In B** menu shown on the next page to adjust the following parameters:

- **5/6 Input** – select the input audio source for Input 5/6.
- **7/8 Input** – select the input audio source for Input 7/8.

When an AES input pair is selected as an input, the corresponding AES BNC on the rear of the module will become an input. If an AES input is not selected, the corresponding BNC on the rear of the module will automatically become an output. Refer to the block diagram on page 4 for an illustration of the input/output BNCs.

- **5/6 Mode** – for a Serial input with embedded audio, select the type of audio in the stream:
 - **Audio** – the embedded stream is standard audio.
 - **Data** – the embedded stream is a non-audio signal.
 - **Auto** – the module will detect the type of signal embedded in the stream, audio or data.
- **7/8 Mode** – select the type of audio in the serial stream as described above.
- **Demux Group** – select the embedded audio group to demultiplex from the selections. The status of embedded audio is shown in the **Embed In** view.

The status of the corresponding audio inputs are shown next to the control. Status is reported as one of the following:

- **No Input** – no serial digital embedded audio is detected.
- **Audio Sync** – the audio embedded in the stream is synchronous with the timing reference.
- **Data Sync** – the data embedded in the stream is synchronous with the timing reference.
- **Audio Async** – the audio embedded in the stream is non-synchronous with the timing reference.

Vid In	Mode	Manual	Config	Proc	Vid Out	Aud Mix A	Aud Mix B
Aud Delay	Aud In A	Aud In B	Aud Out	MetaData	Memory		
5/6 Input		5/6 Status		5/6 Mode			
AES 5/6		No Input		Audio			
7/8 Input		7/8 Status		7/8 Mode			
AES 7/8		No Input		Audio			
DeMux Group		Embed In B					
Group 2		Present					

Use the **Aud Out** menu shown below to adjust the following audio output parameters:

- **Audio Embed A** – turn embedding **Off** for no embedding to take place in the output signal. Select **Replace** to replace the targeted group in the stream with new content. If there is no such group already present, the new content will be placed in the horizontal interval in normal cascade, following any other content already there. When **Cascade** is selected, the audio channels are placed after any existing content. **Replace All** will strip all of the original content and the new content is placed at the beginning of the horizontal interval.
- **Audio Embed B** – identical to **Audio Embed A** but no **Replace All** function is required as this will occur upstream in the A embedder.
- **Mux Group A** – select the multiplexed group to be embedded in embedder A in the output.
- **Mux Group B** – select the multiplexed group to be embedded in embedder B in the output.
- **Dig Ref Level** – set the digital reference level for the audio output.

Vid In	Mode	Manual	Config	Proc	Vid Out	Aud Mix A	Aud Mix B
Aud Delay	Aud In A	Aud In B	Aud Out	MetaData	Memory		
Audio Embed A		Mux Group A					
Replace		Group 1					
Audio Embed B		Mux Group B					
Replace		Group 2					
Dig Ref Level							
-20dBFS							

The **MetaData** menu reports or provides settings for the following closed captioning and timecode parameters:

- **CC Input Line** – You do not need to set the value for this control. If an SD signal is present on the input, the module will autosense which line the caption data is on and report that information in the Captions In box.
- **Captions In** – Reports the status of caption data on the input signal as **None**, **Line 21**, **Line 23**, **CEA608** or **CEA708**.
- **Captions Out** – If the **Captions In** display reports the presence of closed captioning, set to **On** for passing the captions through to the output or turn **Off** closed captioning on the output.
- **Timecode Source** – set the type of timecode source present in the input signal, **LTC**, **VITC Line 14** through **VITC Line 20**.
- **Timecode Output** – set the type of timecode for insertion on the output signal.
- **Timecode Status** display will report **None**, **Line 21**, **Line 23**, **CEA608** or **CEA708**.
- **AFD Out** – set the AFD (Active Format Description) output code for the desired aspect ratio. AFD is a four-bit code that defines the active image area and protected image areas for various combinations of aspect ratios. Available values for this field are:

AFD Auto (default value)

The following additional values represent binary codes:

AFD 0001	AFD 0110	AFD 1011
AFD 0010	AFD 0111	AFD 1100
AFD 0011	AFD 1000	AFD 1101
AFD 0100	AFD 1001	AFD 1110
AFD 0101	AFD 1010	AFD 1111

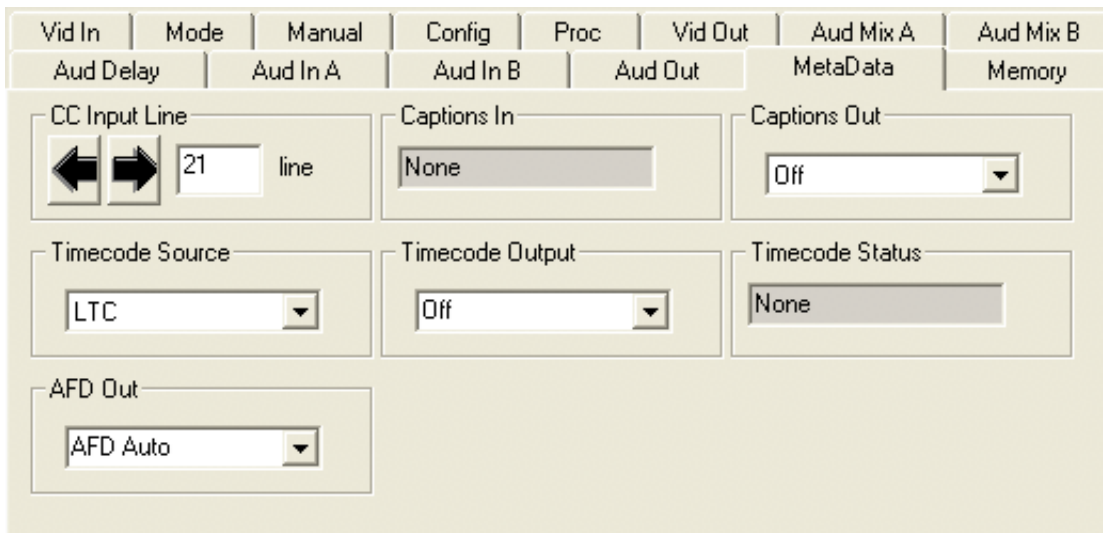

The **Memory** menu shown below allows you to save overall module setups to five memory registers as follows:

- Select **Save**, then one of the five memory registers **Reg 1 – 5**. The box will turn green. The entire module setup is now saved in the selected register.
- To recall a register, select the register box. If there is information saved, the box will turn green. The saved setup will now be loaded to the module. Up to five different module setups can be saved and recalled using the individual registers.

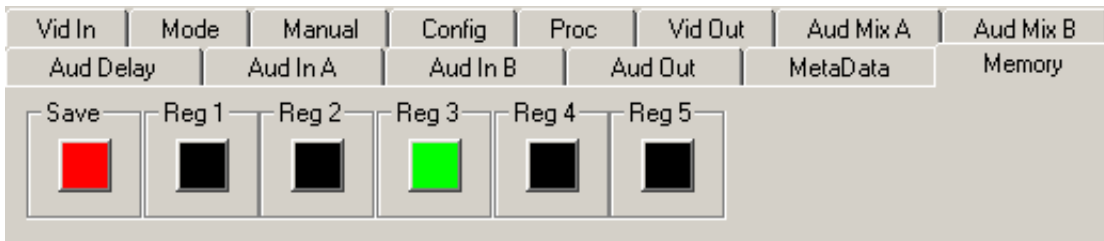

Avenue Touch Screen Remote Configuration

The Avenue Touch Screen remote control menus for this module are illustrated and explained below. Refer to the **7910 Parameter Table** for a summary of available parameters that can be set remotely through the menus illustrated. The **Configuration Summary** gives tips and general background information on setting the parameters. For more information on using Avenue PC, refer to the Avenue PC Control Application Software data pack.

Parameter fields that are grayed out can indicate one of the following conditions:

- An option is not installed.
- The function is not active.
- The module is locked.
- The User Level set with Avenue PC is not accessible from the current User Level.

7910 Avenue Touch Screen Menus

The **Vid In** menu shown below allows you to configure the following:

- **Ref Source** – use this control to set the reference input source.

Status reporting is provided for the following conditions:

- **Input** – indicates signal is present and equalized.
- **WSS/AFD In** – the Wide Screen Signal/Active Format Descriptions In indicator displays the format of the input signal connected to the Video In BNC as one of the following: **None**, **Full Frame**, **Letter 14:9**, **Letter 14:9T**, **Letter 16:9**, **Letter 16:9T**, **Anamorphic**, **Pillar 4x3**, **Pillar 14x9**, **Unknown WSS**, **Unknown AFD**.
- **Reference** – reports the status of the reference input as either **No Reference**, **Ref 525 Lock**, **Ref 625 Lock**, or **Ref TLS Lock**.

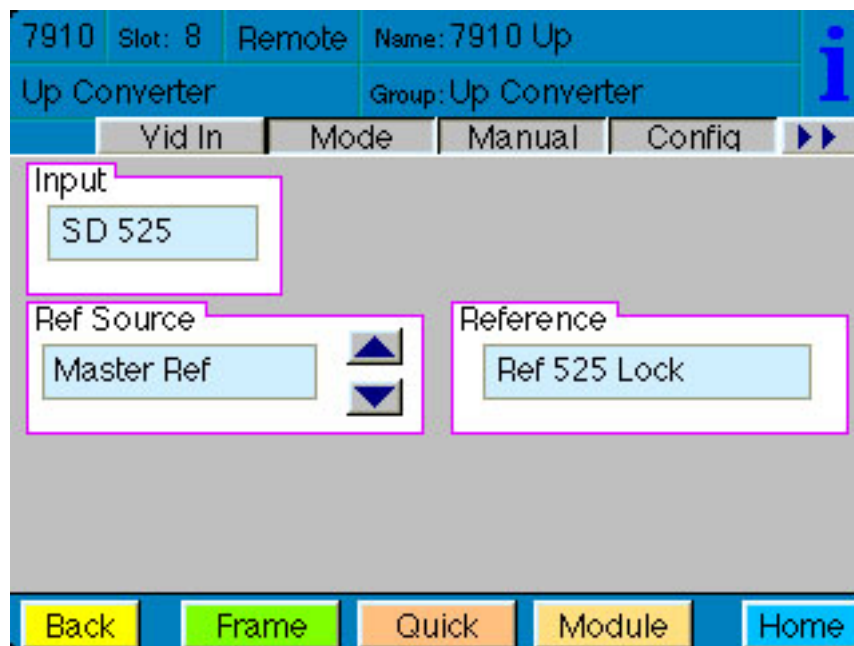

The **Mode** menu shown below allows you to configure the following:

- **Mode** – use this control to set the aspect ratio for the upconverted HD video output. When **Manual** is selected, use the **Manual** menu given next.
- **Output Standard** – use this control to set the desired output standard for upconversion.
- **Up** – use this control to set the desired output aspect ratio when upconverting the input signal (**Anamorphic**, **Letter 16:9**, **Letter 14:9**, **Letter 13:9**, **Pillar**, **Crop Sides 75%**, **Crop Sides 84%**, **Crop Top/Bot**, **WSS/AFD Auto 16x9**, **WSS/AFD Auto 14x9**, **WSS/AFD Auto 4x3**, **Manual**). When **Manual** is selected, use the **Manual** menu to set the aspect ratio.
- **HD Cross** – use this control to set the desired output aspect ratio when cross converting from one type of HD signal to another (**Anamorphic**, **Letter 16:9**, **Letter 14:9**, **Letter 13:9**, **Pillar**, **Crop Sides 75%**, **Crop Sides 84%**, **Crop Top/Bot**, **WSS/AFD Auto 16x9**, **WSS/AFD Auto 14x9**, **WSS/AFD Auto 4x3**, **Manual**). When **Manual** is selected, use the **Manual** menu to set the aspect ratio.

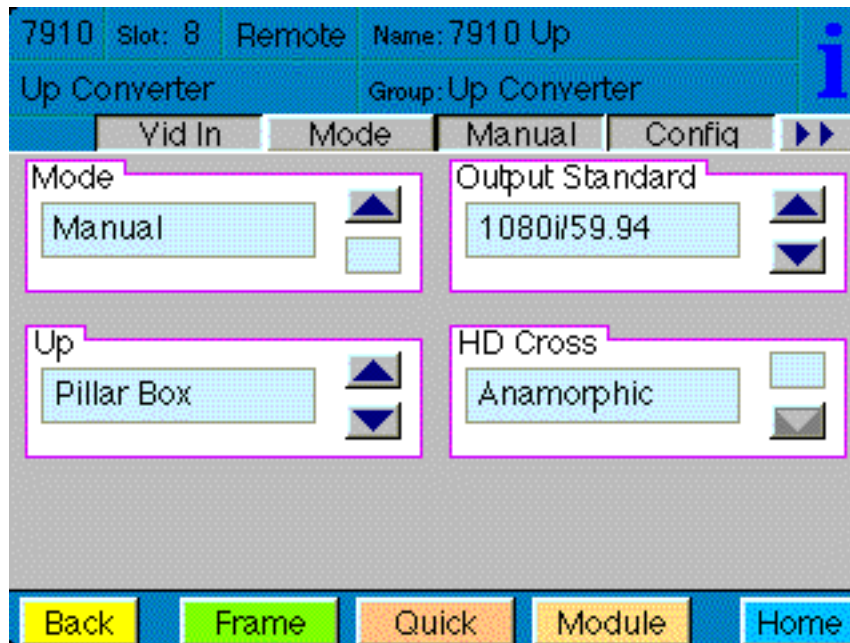

Model 7910 HD Upconverter And Cross Converter

When **Manual** is selected in the **Mode** menu above, you may set the output format mode of the upconverted HD output with the following controls:

- **Width** – set the width of the output .
- **Height** – set the height of the output .
- **Hor Position** – set the horizontal position of the output.
- **Ver Position** – set the vertical position of the output.

Use the **Default** button in each control to return to the default value.

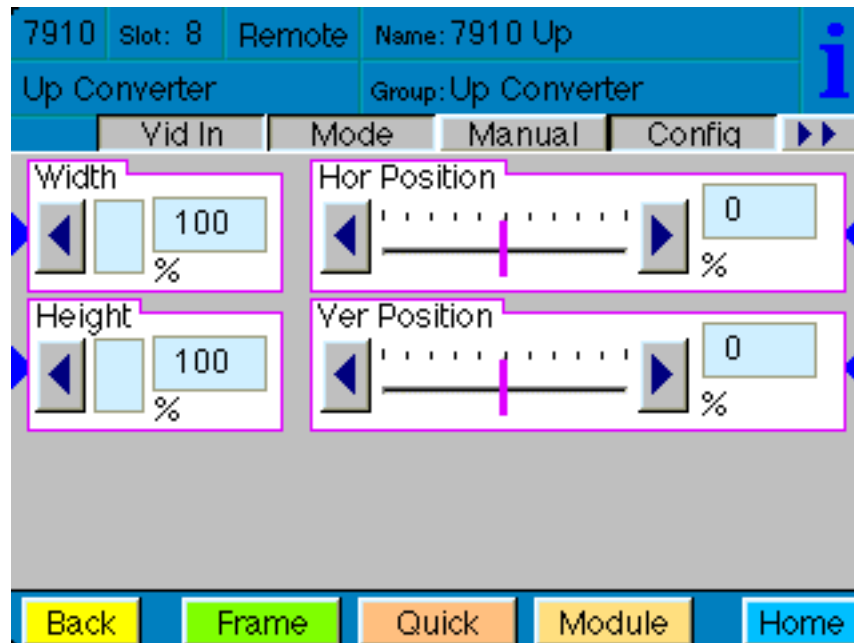

Use the **Config** menu below to enable the following controls:

- **Noise Reduce** – adjusts the amount of noise reduction on the output signal from **Off**, **Low**, **Medium**, or **High**. The typical setting for this parameter is **Off** or **Low**.
- **Detail** – adjusts the amount of picture detail enhancement on the output from **Low**, **Medium**, or **High**. The typical setting for this parameter is **Off** or **Low**.
- **3:2 Detect** – turns the control to detect video that has been converted from film, **On** or **Off**. Use this only for film applications. The typical setting for this parameter is **Off**.

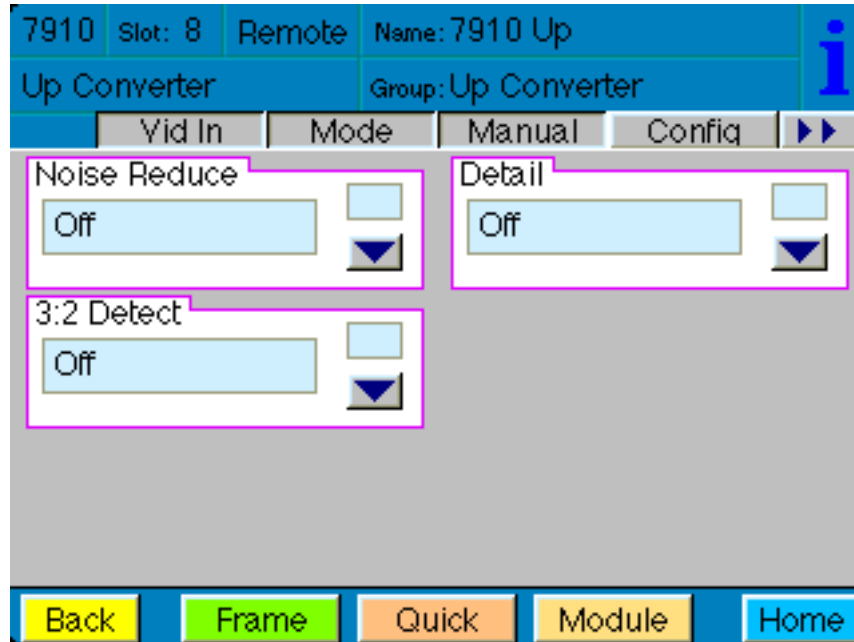

Model 7910 HD Upconverter And Cross Converter

The **Proc** menu shown below allows you to adjust the following video processing parameters for the signal:

- **Gain** – adjust the percentage of overall gain (luminance and chrominance).
- **Chroma** – adjust the percentage of chroma amplitude.
- **Pedestal** – adjust the pedestal (black) level of the signal in IRE.
- **Hue** – adjust the hue of the signal ± 180 degrees.

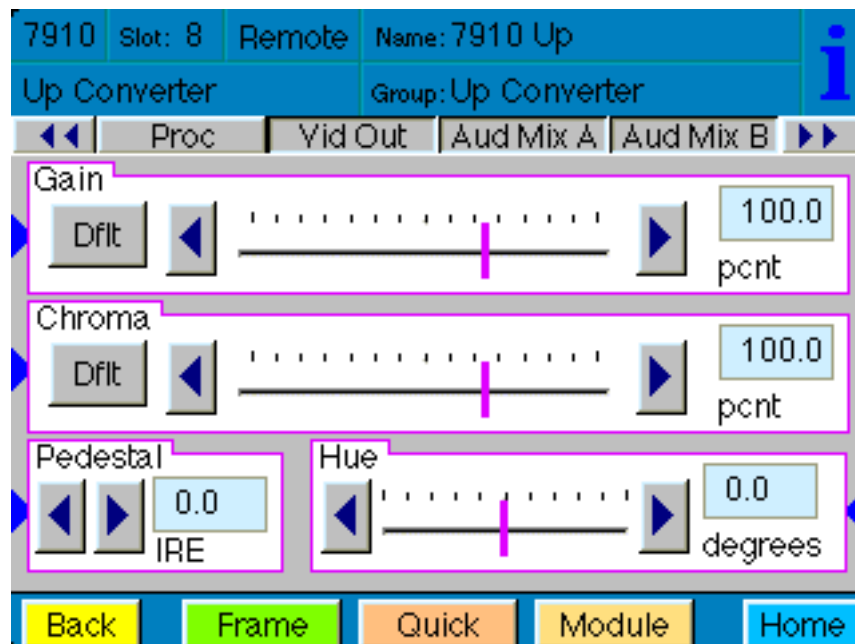

Use the **Vid Out** menu shown below to adjust the following parameters:

- **Test Pattern** – select a test pattern to be sent to the video output of the module.
- **Hor Timing** – adjust the horizontal timing of the output signal to place the leading edge of sync coincident with other sources.
- **Vertical Timing** – set the vertical timing to a typical setting of 0 lines.

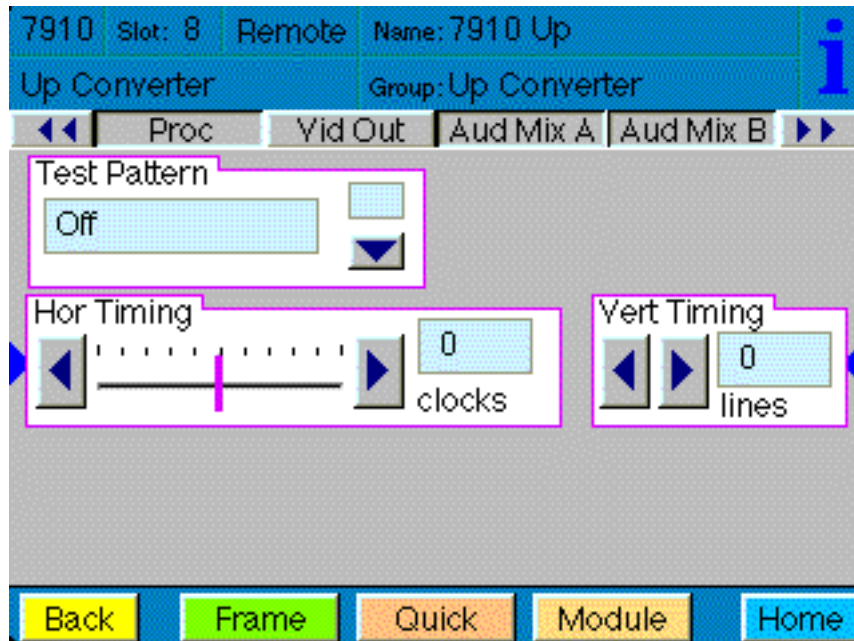

When an 8415 Audio Processor submodule is installed, use the **Aud Mix A** and **B** menus shown next to control the audio mixing and shuffling of the module. Output bus assignments are indicated in green.

For Channels 1 –4, use the **Audio Mix A** menu to set the following:

- **Input Ch 1** – assign Input Channel 1 to the desired output bus or tie to Channel 2. Set the input level using the slider control or by entering a number in the pop-up keypad and pressing the **Enter** key.
- **Input Ch 2** – assign Input Channel 2 to the desired output bus or tie to Channel 1. Set the input level using the slider control or by entering a number in the pop-up keypad and pressing the **Enter** key.
- **Input Ch 3** – assign Input Channel 3 to the desired output bus or tie to Channel 4. Set the input level using the slider control or by entering a number in the pop-up keypad and pressing the **Enter** key.
- **Input Ch 4** – assign Input Channel 4 to the desired output bus or tie to Channel 3. Set the input level using the slider control or by entering a number in the pop-up keypad and pressing the **Enter** key.

Selecting the **Tie** button in Input Ch 1 or Input Ch 2 will tie the two controls together. Selecting the **Tie** button in Input Ch 3 or Input Ch 4 will tie the controls for these channels together.

Select the **Default** button to return to the default value.

Select the **Invert** button to invert the phase of the audio content.

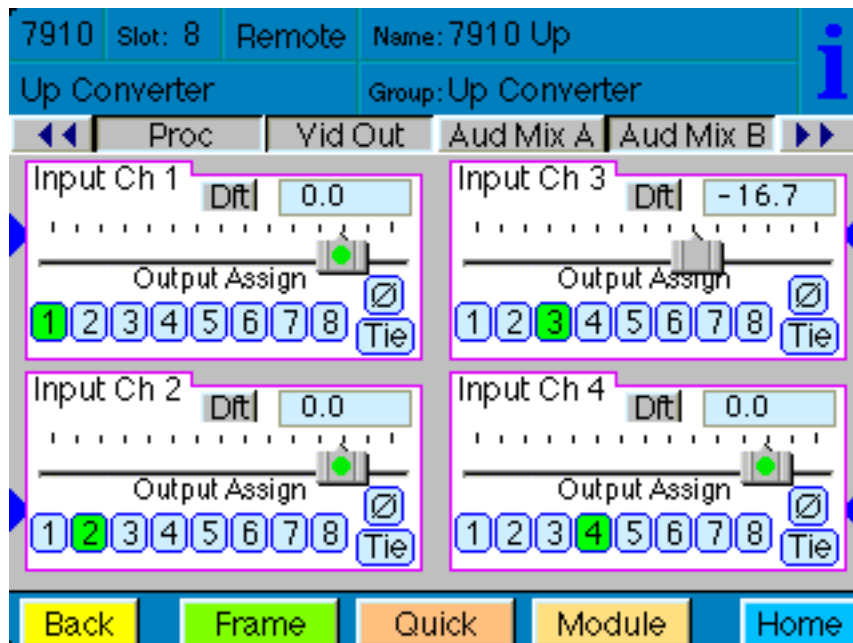

For Channels 5 – 8, use the **Audio Mix B** menu shown below to set the following:

- **Input Ch 5** – assign Input Channel 5 to the desired output bus or tie to Channel 6. Set the input level using the slider control or by entering a number in the pop-up keypad and pressing the **Enter** key.
- **Input Ch 6** – assign Input Channel 6 to the desired output bus or tie to Channel 5. Set the input level using the slider control or by entering a number in the pop-up keypad and pressing the **Enter** key.
- **Input Ch 7** – assign Input Channel 7 to the desired output bus or tie to Channel 8. Set the input level using the slider control or by entering a number in the pop-up keypad and pressing the **Enter** key.
- **Input Ch 8** – assign Input Channel 8 to the desired output bus or tie to Channel 7. Set the input level using the slider control or by entering a number in the pop-up keypad and pressing the **Enter** key.

Selecting the **Tie** button in Input Ch 5 or Input Ch 6 will tie the two controls together. Selecting the **Tie** button in Input Ch 7 or Input Ch 8 will tie the controls for these channels together.

Select the **Default** button to return to the default value.

Select the **Invert** button to invert the phase of the audio content.

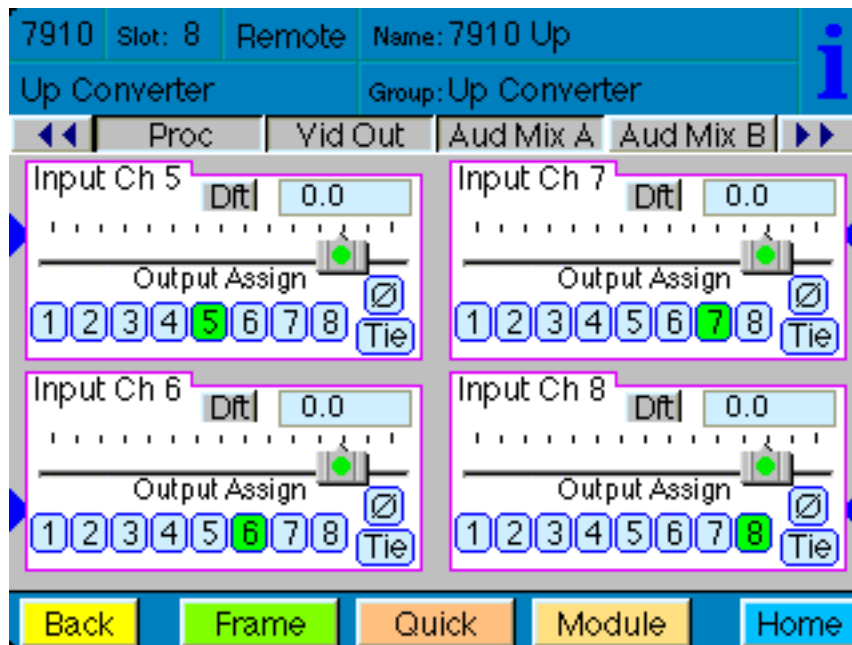

Use the **Aud Delay** menu shown below for the 8415 Audio submodule to adjust the amount of audio delay on the output:

- **Auto Track** – enable auto tracking by selecting **On** or **Off**.
- **Bulk Delay** – set the amount of bulk delay using the left and right arrows or enter a value in the **msec** field with the pop-up keypad and press the **Enter** key.

The amount of total delay will be reported in msec in the **Total Delay** window.

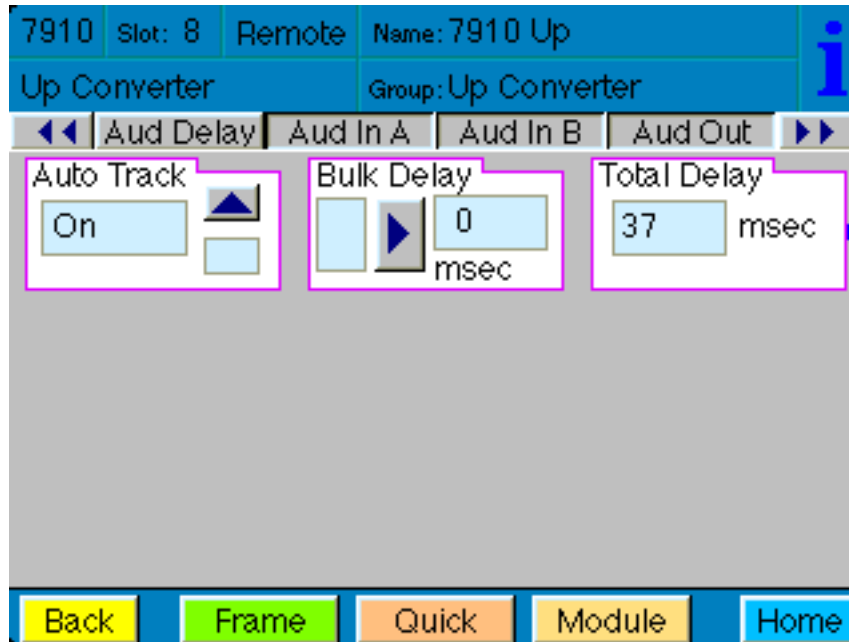

Use the **Aud In A** menu shown on the next page to adjust the following parameters:

- **1/2 Input** – select the input audio source for Input 1/2.
- **3/4 Input** – select the input audio source for Input 3/4.

When an AES input pair is selected as an input, the corresponding AES BNC on the rear of the module will become an input. If an AES input is not selected, the corresponding BNC on the rear of the module will automatically become an output. Refer to the block diagram on page 4 for an illustration of the input/output BNCs.

- **1/2 Mode** – for a Serial input with embedded audio, select the type of audio in the stream:
 - **Audio** – the embedded stream is standard audio.
 - **Data** – the embedded stream is a non-audio signal.
 - **Auto** – the module will detect the type of signal embedded in the stream, audio or data.
- **3/4 Mode** – select the type of audio in the serial stream as described above.
- **DeMux Group** – select the embedded audio group to demultiplex from the selections. The status of embedded audio is shown in the **Embed In** view.

The status of the corresponding audio inputs are shown next to the control. Status is reported as one of the following:

- **No Input** – no serial digital embedded audio is detected.
- **Audio Sync** – the audio embedded in the stream is synchronous with the timing reference.
- **Data Sync** – the data embedded in the stream is synchronous with the timing reference.
- **Audio Async** – the audio embedded in the stream is non-synchronous with the timing reference.

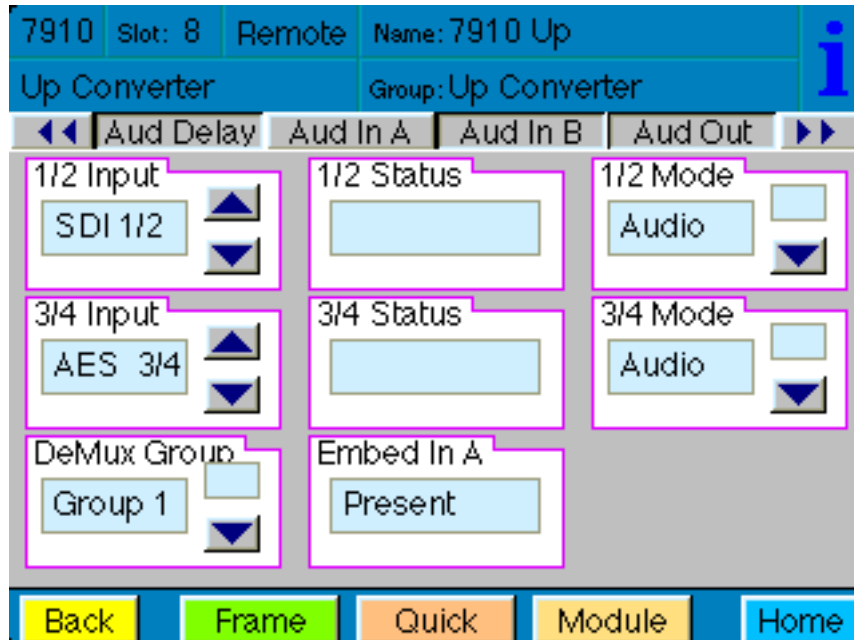

Use the **Aud In B** menu shown on the next page to adjust the following parameters:

- **5/6 Input** – select the input audio source for Input 5/6.
- **7/8 Input** – select the input audio source for Input 7/8.

When an AES input pair is selected as an input, the corresponding AES BNC on the rear of the module will become an input. If an AES input is not selected, the corresponding BNC on the rear of the module will automatically become an output. Refer to the block diagram on page 4 for an illustration of the input/output BNCs.

- **5/6 Mode** – for a Serial input with embedded audio, select the type of audio in the stream:
 - **Audio** – the embedded stream is standard audio.
 - **Data** – the embedded stream is a non-audio signal.
 - **Auto** – the module will detect the type of signal embedded in the stream, audio or data.
- **7/8 Mode** – select the type of audio in the serial stream as described above.
- **DeMux Group** – select the embedded audio group to demultiplex from the selections. The status of embedded audio is shown in the **Embed In** view.

Model 7910 HD Upconverter And Cross Converter

The status of the corresponding audio inputs are shown next to the control. Status is reported as one of the following:

- **No Input** – no serial digital embedded audio is detected.
- **Audio Sync** – the audio embedded in the stream is synchronous with the timing reference.
- **Data Sync** – the data embedded in the stream is synchronous with the timing reference.
- **Audio Async** – the audio embedded in the stream is non-synchronous with the timing reference.

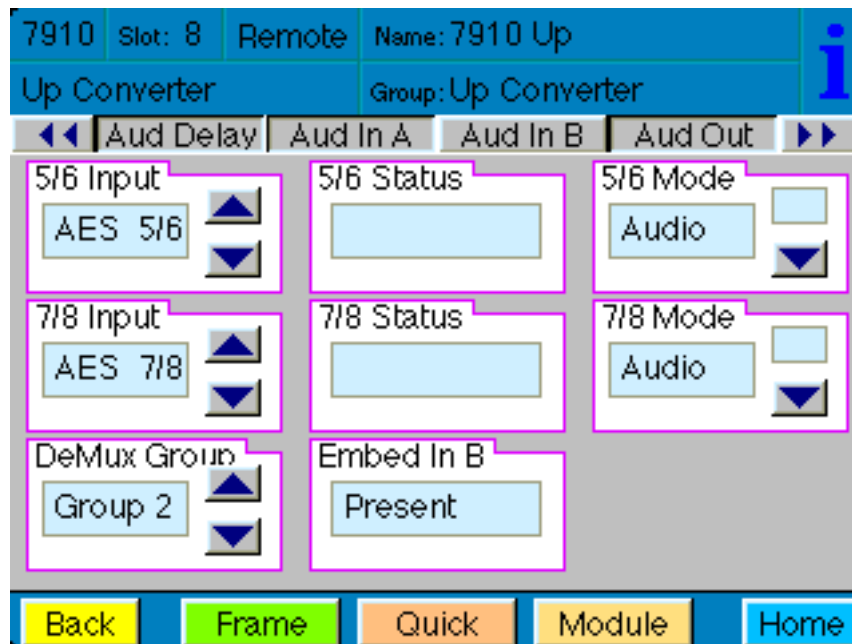

Use the **Aud Out** menu shown below to adjust the following audio output parameters:

- **Audio Embed A** – turn embedding **Off** for no embedding to take place in the output signal. Select **Replace** to replace the targeted group in the stream with new content. If there is no such group already present, the new content will be placed in the horizontal interval in normal cascade, following any other content already there. When **Cascade** is selected, the audio channels are placed after any existing content. **Replace All** will strip all of the original content and the new content is placed at the beginning of the horizontal interval.
- **Audio Embed B** – identical to **Audio Embed A** but no **Replace All** function is required as this will occur upstream in the A embedder.
- **Mux Group A** – select the multiplexed group to be embedded in embedder A in the output.
- **Mux Group B** – select the multiplexed group to be embedded in embedder B in the output.
- **Dig Ref Level** – set the digital reference level for the audio output.

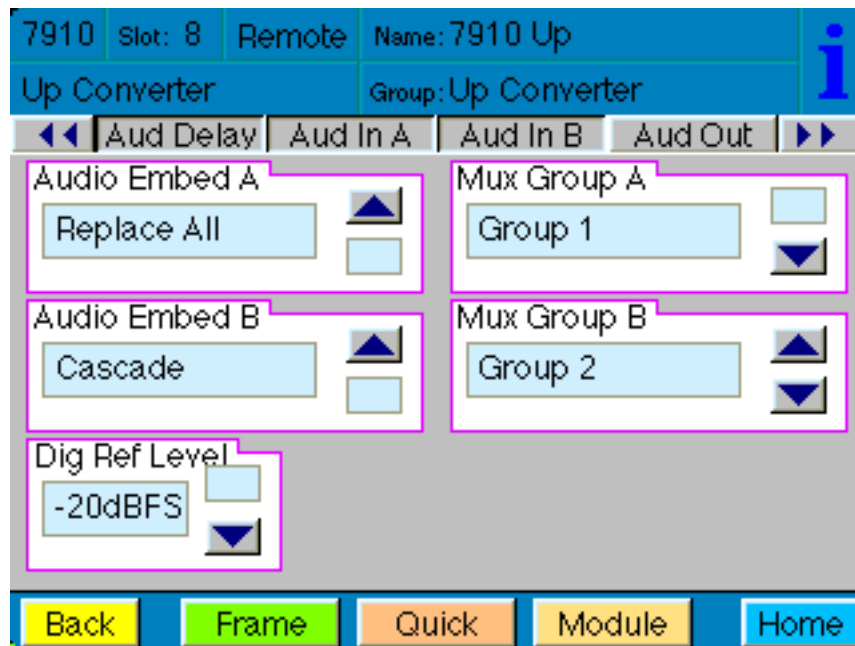

The **MetaData** menu reports or provides settings for the following closed captioning and timecode parameters:

- **CC Input Line** – You do not need to set the value for this control. If an SD signal is present on the input, the module will autosense which line the caption data is on and report that information in the Captions In box.
- **Captions In** – Reports the status of caption data on the input signal as **None**, **Line 21**, **Line 23**, **CEA608** or **CEA708**.
- **Captions Out** – If the **Captions In** display reports the presence of closed captioning, set to **On** for passing the captions through to the output or turn **Off** closed captioning on the output.
- **Timecode Source** – set the type of timecode source present in the input signal, **LTC**, **VITC Line 14** through **VITC Line 20**.
- **Timecode Output** – set the type of timecode for insertion on the output signal.
- **Timecode Status** display will report **None**, **Line 21**, **Line 23**, **CEA608** or **CEA708**.
- **AFD Out** – set the AFD (Active Format Description) output code for the desired aspect ratio. AFD is a four-bit code that defines the active image area and protected image areas for various combinations of aspect ratios. Available values for this field are:

AFD Auto (default value)

The following additional values represent binary codes:

AFD 0001	AFD 0110	AFD 1011
AFD 0010	AFD 0111	AFD 1100
AFD 0011	AFD 1000	AFD 1101
AFD 0100	AFD 1001	AFD 1110
AFD 0101	AFD 1010	AFD 1111

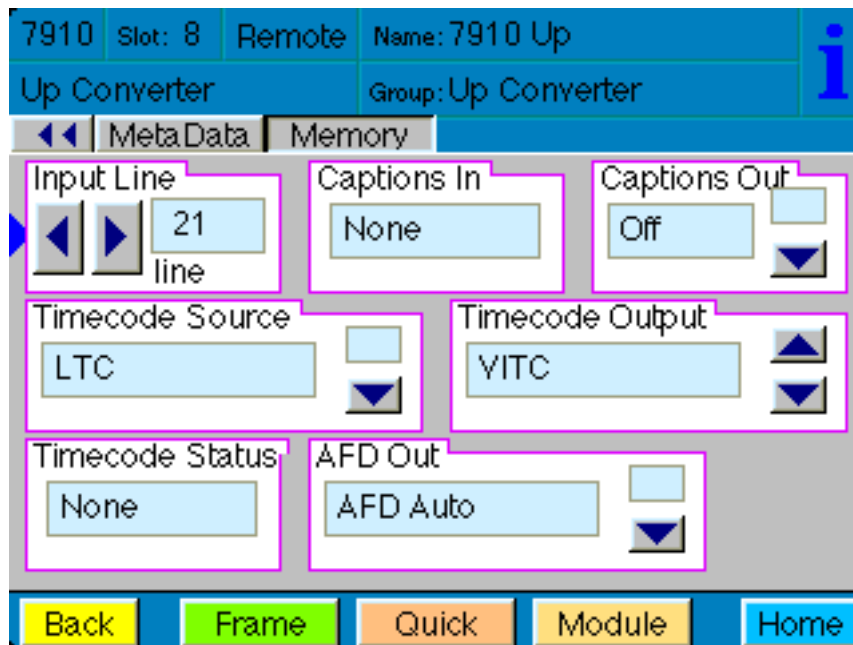

The **Memory** menu shown below allows you to save overall module setups to five memory registers as follows:

- Select **Save**, then one of the five memory registers **Reg 1 – 5**. The box will turn green. The entire module setup is now saved in the selected register.
- To recall a register, select the register box. If there is information saved, the box will turn green. The saved setup will now be loaded to the module. Up to five different module setups can be saved and recalled using the individual registers.

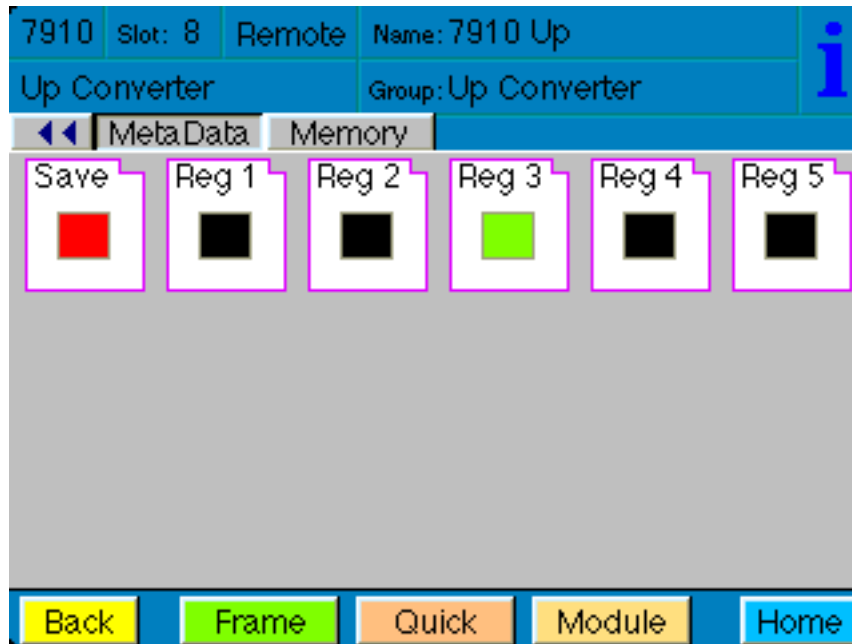

TROUBLESHOOTING

As a troubleshooting aid, the signal presence, power and CPU status can be easily monitored from the front panel of this module using the indicators explained in the **Front Panel Switches and Indicators** section.

The following status items can be monitored using the Avenue Touch Screen Control Panel, Express Panel, or PC Application:

- Input Status
- Slot ID, Software Version and Board Revision

Refer to the overall troubleshooting tips given below for the module:

No status lights are lit on front panel:

- Check that frame power is present (green LED{s} on frame power supplies).
- Check that module is firmly seated in frame. Try removing it and plugging it in again.

Can't control module:

- Check status of CPU **Run** green LED. Should be blinking slowly and in unison with other modules if System module is present. If not, try removing it and plugging it in again.
- System module may not be working properly if installed.

No video or audio signal out of module:

- Check status of **In** green LEDs. If not lit, check the input signal for presence and quality.
- Check cabling to input of module.

You may also refer to the technical support section of the Ensemble web site for the latest information on your equipment at the URL below:

<http://www.ensembledesigns.com/support>

SOFTWARE UPDATING

Software upgrades for each module can be downloaded remotely if the optional System Control module is installed. These can be downloaded onto your PC and Avenue PC will distribute the update to the individual module. (Refer to the Avenue PC documentation for more information.) Periodically updates will be posted on our web site. If you do not have the required System Control Module and Avenue PC, modules can be sent back to the factory for software upgrades.

WARRANTY AND FACTORY SERVICE

Warranty

This Module is covered by a five year limited warranty, as stated in the main Preface of this manual. If you require service (under warranty or not), please contact Ensemble Designs and ask for customer service before you return the unit. This will allow the service technician to provide any other suggestions for identifying the problem and recommend possible solutions.

Factory Service

If you return equipment for repair, please get a Return Material Authorization Number (RMA) from the factory first.

Ship the product and a written description of the problem to:

Ensemble Designs, Inc.

Attention: Customer Service RMA #####

870 Gold Flat Rd.

Nevada City, CA. 95959 USA

(530) 478-1830

Fax: (530) 478-1832

service@ensembledesigns.com

<http://www.ensembledesigns.com>

Be sure to put your RMA number on the outside of the box.

SPECIFICATIONS

7910 HD Upconverter

Serial Digital Input:

Number: One
Signal Type: SD Serial Digital 270 Mb/s
SMPTE 259M
(both 525 and 625 SD standards)
HD Serial Digital 1.485 Gb/s
SMPTE 274M, 292M, or 296M
Impedance: 75 Ω , BNC
Return Loss: >15 dB
Maximum Cable Length:
270 Mb/s 300 meters (Belden 1694A or equivalent)
1.485 Gb/s 100 meters (Belden 1694A or equivalent)

Serial Digital Output

Number: Four
Type: HD Serial Digital 1.485 Gb/s
SMPTE 274M or 296M
Impedance: 75 Ω , BNC
Return Loss: >15 dB
Output DC: None (AC coupled)

HD Standards Supported

1080i (SMPTE 274M -4,5,6) 50, 59.94, 60 Hz
720p (SMPTE 296M -1,2,3) 50, 59.94, 60Hz
1080p (SMPTE 274M -9,10,11) 23.98, 24, 25 Hz
1080sF (RP211 -14,15,16) 23.98, 24, 25 Hz

Reference Input

Number: One external (module's BNC)
One internal (frame master ref BNC)
Signal Type: PAL or NTSC composite video
or HD Tri-Level Sync
SMPTE 274M or 296M
Return Loss: >40 dB (applies to external ref input)

Conversion Directions

Upconversion between:
525 (NTSC) and 1080i/59.94, 720p/59.94, 1080p/23.98, 1080sF/23.98
625 (PAL) and 1080i/50, 720p/50, 1080p/25, 1080sF/25

Cross Conversion within frame rate families:

525 Derived Family: 1080i/59.94, 720p/59.94, 1080p/23.98, and 1080sF/23.98
625 Derived Family: 1080i/50, 720p/50, 1080p/25, 1080sF/25

AES/EBU Digital Inputs

Number:	Four (total of eight channels)
Type:	AES3id
Connectorization:	Coaxial, 75 Ω BNC
Bit Depth:	20 or 24 Bit
Sample Rate:	30 kHz to 100 kHz (sample rate converted internally to 48 kHz)
Crosstalk:	< 144 dB
Dynamic Range:	> 144 dB
Reference Level:	-18 or -20 dBFS (Selectable)
AC-3, Dolby-E:	Supported when inputs are synchronous

Embedded Inputs

Number:	Four AES streams (from video input) Eight channels from any two of four groups Selectable to any of four groups
Type:	SMPTE 274M Compliant Selectable to any of four groups
Channels:	Eight
Bit Depth:	20 or 24 Bit

AES/EBU Digital Outputs

Number:	Four (total of eight channels)
Type:	AES3id
Connectorization:	Coaxial, 75 Ω BNC
Bit Depth:	20 or 24 Bit
Sample Rate:	48 kHz Synchronous to Video output
Reference Level:	-18 or -20 dBFS (Selectable)

Embedded Output

Number:	Four or two, depending on configuration
Group Assign:	Cascade, or Replace any of two of four groups
Channels:	Eight
Bit Depth:	24 Bit

General Specifications

Power Consumption:	< 10 Watts
Temperature Range:	0 to 40 degrees C ambient (all specs met)
Relative Humidity:	0 to 95% noncondensing
Altitude:	0 to 10,000 ft

Due to ongoing product development, all specifications subject to change.