

Model 7400 HD/SD and Model 9400 3G/HD/SD Sync Pulse Generator and Test Signal Generator User Guide including 7400-GPS Option



Revision 1.5 SW v2.2.7

ENSEMBLE

D E S I G N S

Purveyors of Fine Video Gear—Loved by Engineers Worldwide

Clearly, Ensemble wants to be in the broadcast equipment business. It's so rare anymore to find a company of this caliber that has not been gobbled up by a large corporation. They are privately held so they don't have to please the money people. They really put their efforts into building products and working with customers.

I'm really happy with the Avenue products and Ensemble's service, and even more important my engineers are happy. We've continued to upgrade the product and add more cards. We will be rebuilding our production control room and we will use Avenue again.

~ Don McKay, Vice President Engineering, Oregon Public Broadcasting

Who is Ensemble Designs?

By Engineers, For Engineers

In 1989, a former television station engineer who loved designing and building video equipment, decided to start a new company. He relished the idea of taking an existing group of equipment and adding a few special pieces in order to create an even more elegant ensemble. So, he designed and built his first product and the company was born.



Avenue frames handle 270 Mb/s, 1.5 Gb/s and 3 Gb/s signals, audio and MPEG signals. Used worldwide in broadcast, mobile, production, and post.

Focused On What You Need

As the company has grown, more former TV station engineers have joined Ensemble Designs and this wealth of practical experience fuels the company's innovation. Everyone at the company is focused on providing the very equipment you need to complete your ensemble of video and audio gear. We offer those special pieces that tie everything together so that when combined, the whole ensemble is exactly what you need.

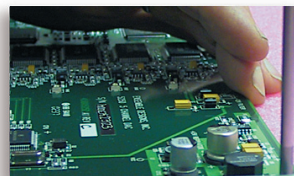

We're focused on processing gear—3G/HD/SD/ASI video, audio and optical modules.

Notably Great Service for You

We listen to you – just tell us what you need and we'll do our best to build it. We are completely focused on you and the equipment you need. Being privately held means we don't have to worry about a big board of directors or anything else that might take attention away from real business. And, you can be sure that when you call a real person will answer the phone. We love this business and we're here to stay.



Come on by and visit us. Drop in for lunch and a tour!

Bricks and Mortar of Your Facility

The bricks and mortar of a facility include pieces like up/downconverters, audio embedders, video converters, routers, protection switches and SPGs for SD, HD and 3Gb/s. That's what we're focused on, that's all we do – we make proven and reliable signal processing and infrastructure gear for broadcasters worldwide, for you.



Shipped with care to television broadcasters and video facilities all over the world.



Contents

Module Overview	5
7400 and 9400 SPG/TSG—Reliable and Easy-To-Use	5
Favorite Test Patterns	5
Customizable Test Patterns	5
Audio Generators	6
Multiple Timecode Generators	6
7400-GPS Option for the Ultimate Precision Reference	7
Functional Block Diagram	8
Applications	9
A Complete SPG and TSG System	9
Broadcast	10
Mobile Applications	11
Post Production	12
Custom Test Patterns	12
Timecode	13
How the Timecode is Generated	13
Analog Timecode	13
Vertical Interval Timecode (VITC) and Digital Vertical Interval Timecode (DVITC)	14
Locking to a Black Burst Signal with VITC	14
Audio Generation and Routing	15
Audio Generators	15
Support for Analog and Digital Audio	15
Sixteen Independently Programmable Audio Channels Per Generator	15
Audio Embedded in the SDI Outputs	15
Installation	17
7400-GPS Option Field Installation Procedure	17
<i>7400-GPS Option Kit</i>	17
<i>Securing the 7400-GPS Option Submodule to the 7400 or 9400 Main Module</i>	18
<i>Connecting the Cables between the 7400-GPS Option Submodule and the 7400 or 9400 Main Module</i>	19
<i>H1 Jumper Positioning</i>	20
<i>Safety and Outdoor Antenna Grounding</i>	21

Cabling	22
Generator A	24
Generator B	24
Module Configuration and Control	25
Front Panel Controls and Indicators	25
Avenue PC and Touch Screen Remote Configuration	26
7400 and 9400 Avenue PC and Touch Screen Menus	27
<i>Sync Pulse Generator A Menu</i>	27
<i>Test Signal Generator A Menu</i>	29
<i>Timing A Menu</i>	32
<i>Programmable Output 1 A Menu</i>	33
<i>Programmable Outputs 2 A and 3 A Menu</i>	35
<i>Audio Generator A Menu</i>	38
<i>Timecode A Menu</i>	40
<i>Misc A Menu: Setting the Slate, Closed Caption, and Aspect Ratio Parameters</i>	42
<i>Sync Pulse Generator B Menu</i>	44
<i>Test Signal Generator B Menu</i>	46
<i>Timing B Menu</i>	49
<i>Programmable Output 1 B Menu</i>	50
<i>Programmable Output 2 B and 3 B Menu</i>	52
<i>Audio Generator B Menu</i>	55
<i>Timecode B Menu</i>	57
<i>Misc B Menu: Setting the Slate, Closed Caption, and Aspect Ratio Parameters</i>	59
<i>Global Menu</i>	61
<i>GPS Menu</i>	63
<i>Storage Menu</i>	66
Troubleshooting	67
<i>No Generator A or Generator B LED indication</i>	67
<i>Cannot control module</i>	67
<i>Module controls are grayed out</i>	67
<i>No signal out of module</i>	67
Software Updating	68
Warranty and Factory Service	69
Specifications for Models 7400 and 9400	70
Glossary	73

Module Overview

7400 and 9400 SPG/TSG—Reliable and Easy-To-Use

The 7400 HD/SD and the 9400 3G/HD/SD Sync Generator and Test Signal Generator provide a stable timing source that is perfect for local reference generation in broadcast, remote trucks and post. HD SDI, SD SDI, analog composite, HD Tri-Level Sync, timecode, AES audio and analog audio reference outputs are generated.

The 7400 and 9400 can operate from an internal precision frequency reference as a stand-alone Master Sync Generator or lock to a video reference or 10 MHz precision reference. Alternately, the 7400-GPS option can be used.

The 7400 and 9400 can output multiple formats of Tri-Level Sync, HD SDI test signals (1.5 Gb/s for the 7400, and 3 Gb/s and 1.5 Gb/s for the 9400), SD composite and SDI test signals, and color black reference. The 7400 and 9400 can simultaneously deliver both 525 (NTSC) and 625 (PAL) based signals. Color framing tracks the reference signal. All of the video outputs are derived from the same time base and can be timed with respect to each other. The 7400 and 9400 each have two identical generators, Generator A and Generator B, both with a variety of outputs. Each set of outputs can be timed with respect to the reference to any point in the television frame. All of the Outputs from a particular Generator must be selected within the same frame rate family:

- 50 Hz (625) Derived Family: 1080i/50, 720p/50, 1080p/25, 1080sF/25, 625i/50
- 59.94 Hz (525) Derived Family: 1080i/59.94, 720p/59.94, 1080p/23.98, 1080sF/23.98, 525i/59.94
- 60 Hz Derived Family: 1080i/60, 720p/60, 1080p/24, 1080sF/24

The Avenue Frame features a retainer bar to ensure that modules remain properly seated even in the most demanding mobile environments.

Favorite Test Patterns

There are over 30 test signals including: Full and Split Field Bars at 75% and 100% with Pluge, Black, Flat Field, Pulse and Window, Ramp, Crosshatch, Safe Title, Blanking Markers, Cosite, Checkfield, Pathogenic, and 5 Step. The Cyclops feature adds a motion element to the selected video test signal to assist in locating a signal that might be frozen in a frame sync somewhere in the signal chain. An ID slate with user programmable text can overlay the test pattern.

Customizable Test Patterns

In addition to the standard suite of test patterns, users can create custom test patterns on a computer. Simply transfer test patterns to the included Secure Digital flash memory card using Avenue Logo software and a standard card reader, then insert the memory card into the 7400 or 9400. Test patterns can include motion.

Audio Generators

The 7400 and 9400 provide extensive support for analog and digital audio. Because all of the video outputs can be locked to a common time base, the AES digital audio outputs are always synchronous with all of the video outputs – regardless of format. Multiple tone generators make it easy to identify multi-channel content. This bitstream will be included in the set of signals that can be embedded into the test signal outputs.

The audio section of each generator supports sixteen audio channels. The content of each channel is independently programmable. Choices include adjustable frequency tone generators, tone sweeps, Silence, Timecode, Audio Clip playback from Secure Digital Card, and the external AES input. Left/Right Channel ID that synchronizes to the Cyclops feature can also be selected.

All sixteen of these channels can be embedded in the SDI outputs. Each AES output can select from any of the 8 pairs that make up these 16 channels. Similarly, the stereo analog output of each generator can be driven from any of these audio signal pairs.

Multiple Timecode Generators

Multiple timecode generators make the 7400 and 9400 convenient for post applications. Timecode is delivered as LTC (both 75 Ohm BNC and 110 Ohm Balanced), VITC, and DVITC. One generator can be configured to produce 525/59.94 drop frame timecode while the other generator is making 1080sF/23.98.

7400-GPS Option for the Ultimate Precision Reference

For the ultimate in precision, the 7400-GPS option can be used with the 7400 and 9400 modules. The purpose of this GPS option is to provide an extremely precise frequency reference. The oscillator on the 7400-GPS is more accurate than a typical internal precision standard and is equivalent in accuracy to an atomic standard. Increased frequency accuracy makes it possible to frame synchronize signals between different facilities with virtually no dropped or doubled frames. The GPS option also provides precise time of day information, which can be used to drive the 7400 or 9400 module's internal timecode generators.

The 7400-GPS option seamlessly integrates into the Avenue system by plugging directly onto the 7400 and 9400 modules. It can be easily installed in the field. The 7400-GPS option consists of a compact, weatherproof antenna (with internal high-gain pre-amp) and a receiver sub module which mounts directly to the 7400 or 9400 module. The included GPS antenna mounts onto standard 3/4" threaded pipe, metal or plastic. Connection from the F-style coaxial fitting on the antenna to the appropriate BNC on the Avenue Frame can be made with customer supplied standard 75 ohm cable. The coax cable can be routed through the center of the pipe for a completely waterproof installation. When low loss cable such as Belden 1694A is used, the antenna can be placed up to 200 feet (60 meters) from the frame. Ideally, the antenna is mounted outdoors where it has an unobstructed view of the sky.

For your reference a functional block diagram for the 7400 and 9400 follows, first as a portrait view and then as a full page landscape view.

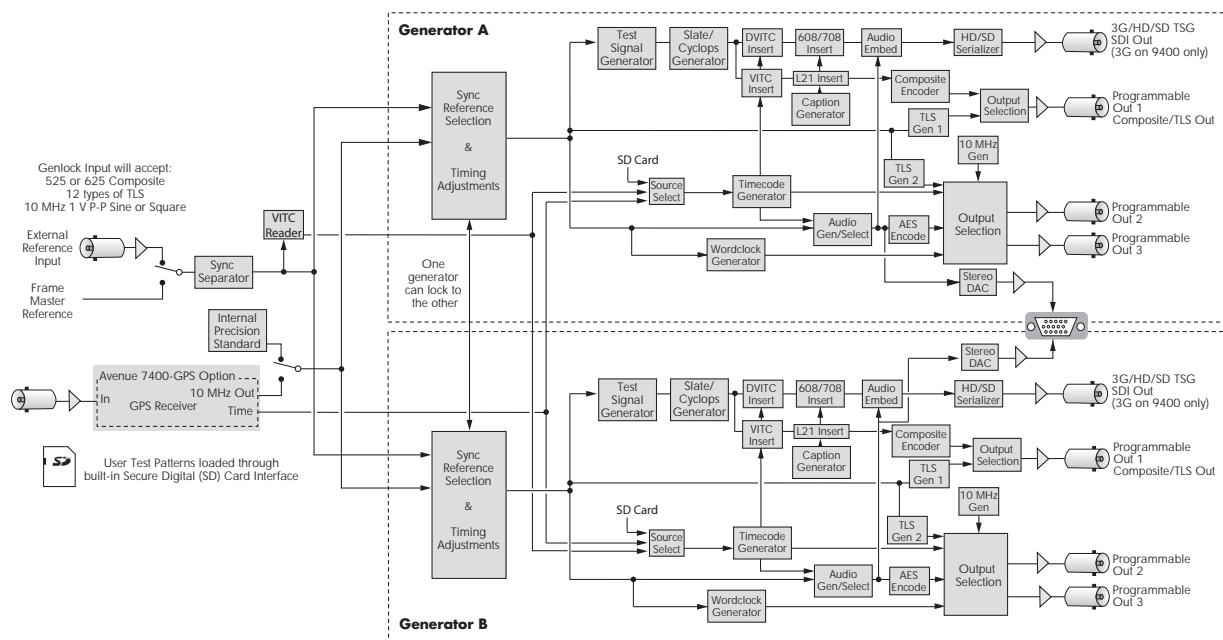

Functional Block Diagram, portrait view

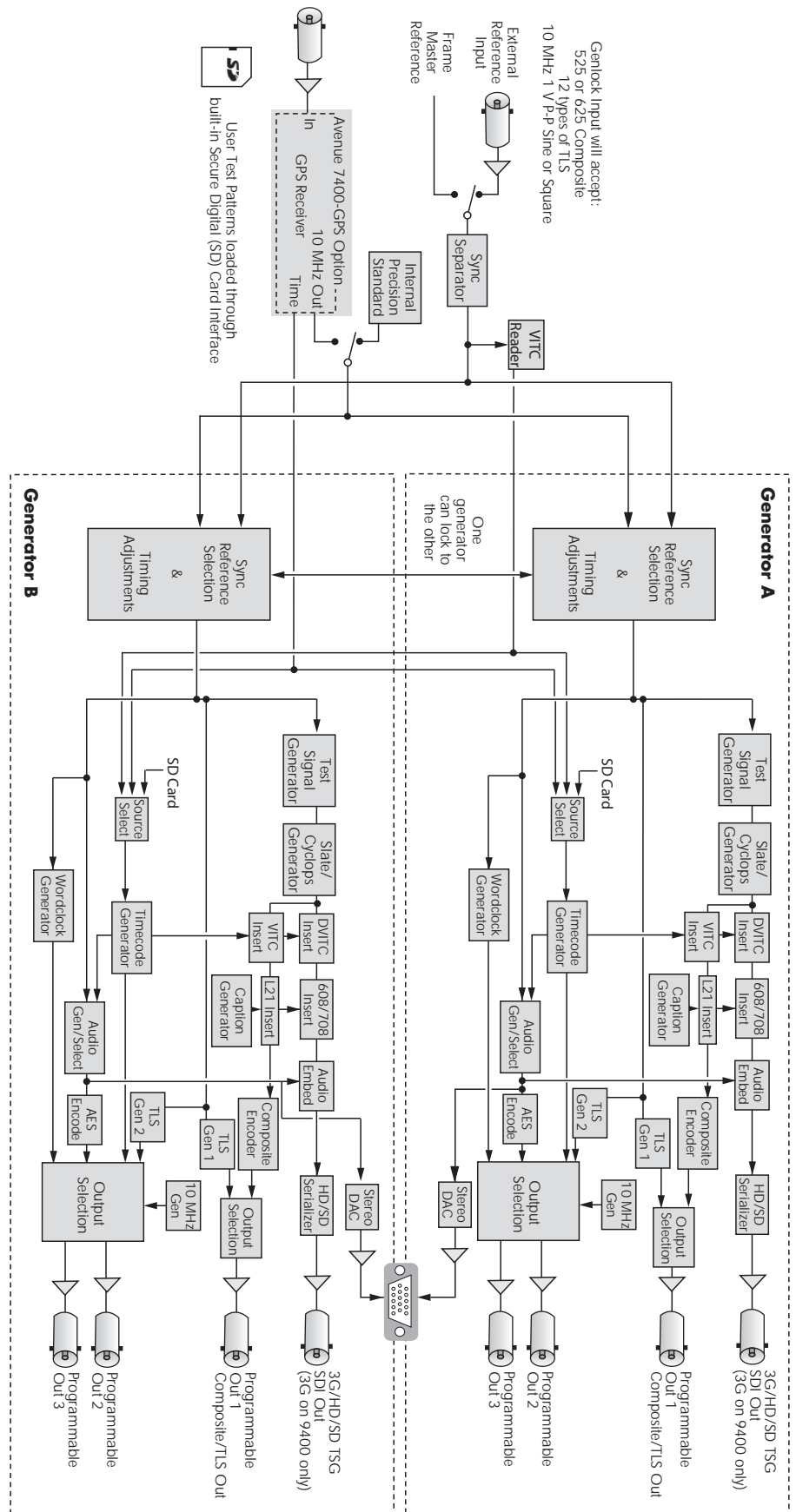

Functional Block Diagram, Landscape view

Applications

A Complete SPG and TSG System

The 7400 and 9400 can be combined with other Avenue modules to create a complete sync pulse and test signal chain. The application shown below illustrates how the 9400 module provides digital, analog and audio reference outputs which can be distributed throughout a facility when combined with the 9125 Dual DA and the 5150 DA. The 5150 distribution amplifier can be used to distribute multiple copies of AES audio, Tri-Level Sync or composite black signals as needed. For distribution of 3G signals, the 9125 Dual DA is a good fit.

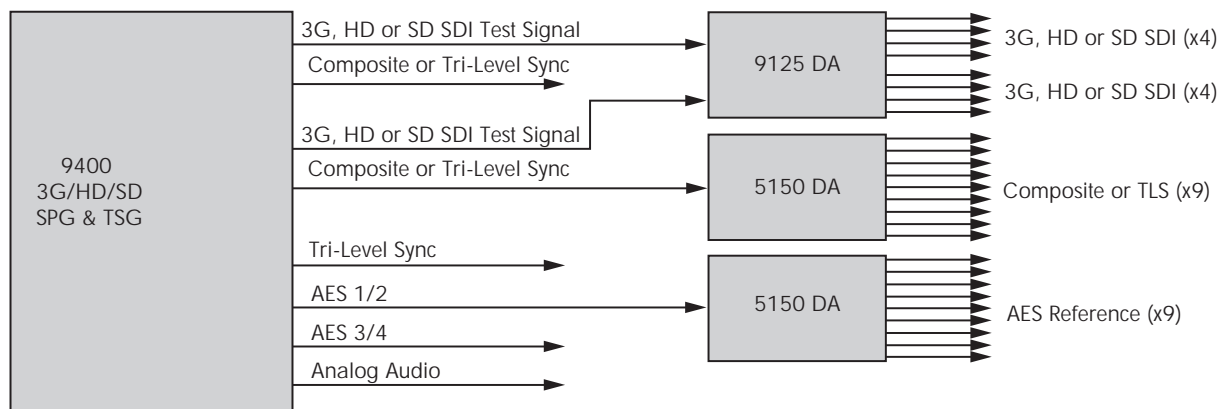

A Complete Sync Pulse and Test Signal Chain Example Using 9400

Broadcast

The Avenue 7400 and 9400 provide a comprehensive set of signals for TV stations. Analog sync, SD bars and black, HD bars and black and audio reference are simultaneously available. You can even output multiple kinds of Tri-Level Sync to support all of your HD equipment. Programmable outputs allow you to select the signals you need for your station. An external AES source can be embedded into your test patterns as well. Avenue sync changeover and redundant power options offer added security.

7400 Broadcast Application Configuration Example

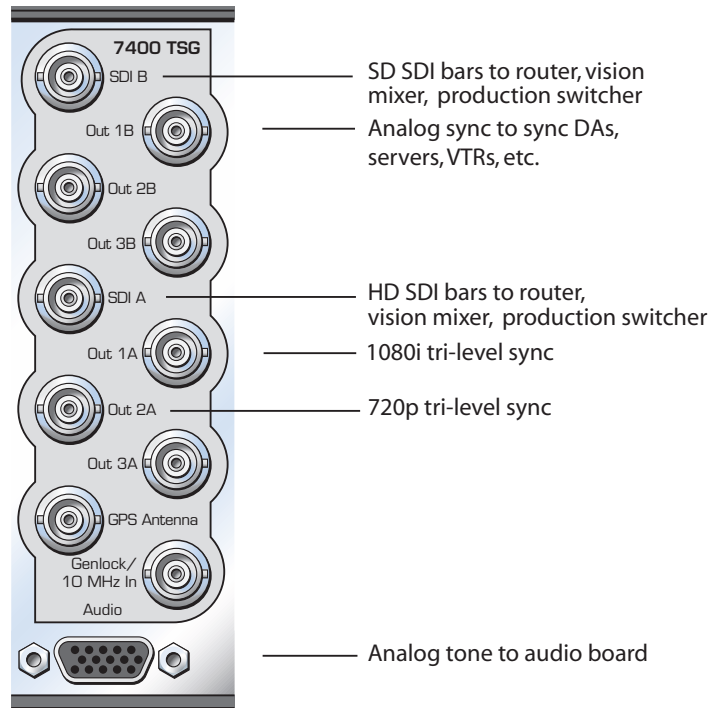

9400 Broadcast Application Configuration Example

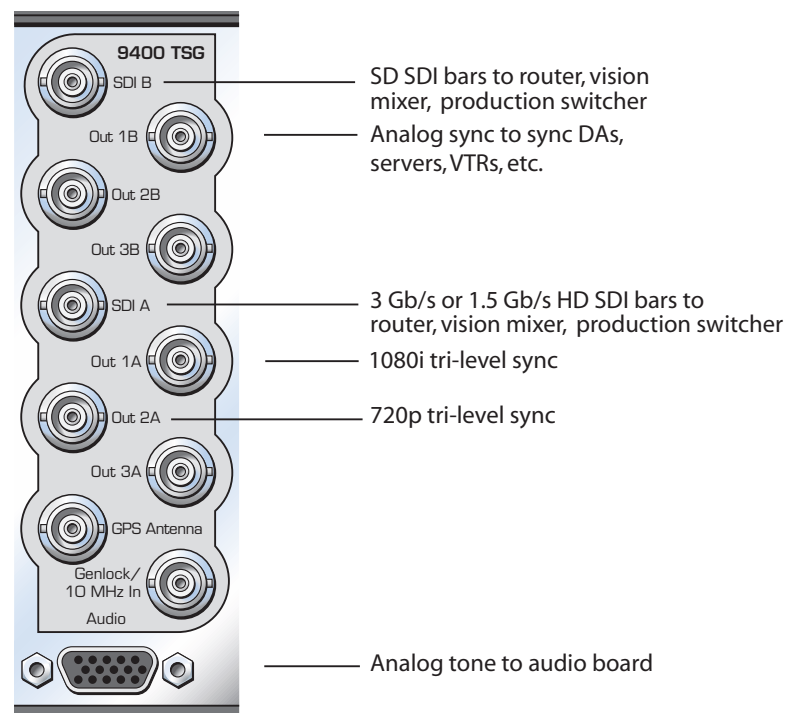

Mobile Applications

All of the Avenue SPG/TSGs are rugged enough for use in mobile trucks, ENG and helicopters. The Avenue frame has a retainer bar on it that ensures modules in the frame are completely stable. The Avenue 7400 and 9400 have a wide range of test signals to choose from. Test patterns can have a moving element so that you can be sure that a signal is not frozen in a frame sync somewhere in the signal chain. Time code is available on BNC and 15 pin D for your convenience. The 7400 GPS option is integrated nicely onto the main 7400 or 9400. The GPS antenna connects to a BNC on the 7400 or 9400 module providing precision timing accuracy along with timecode data and date and time insertion.

7400 Mobile Application Configuration Example

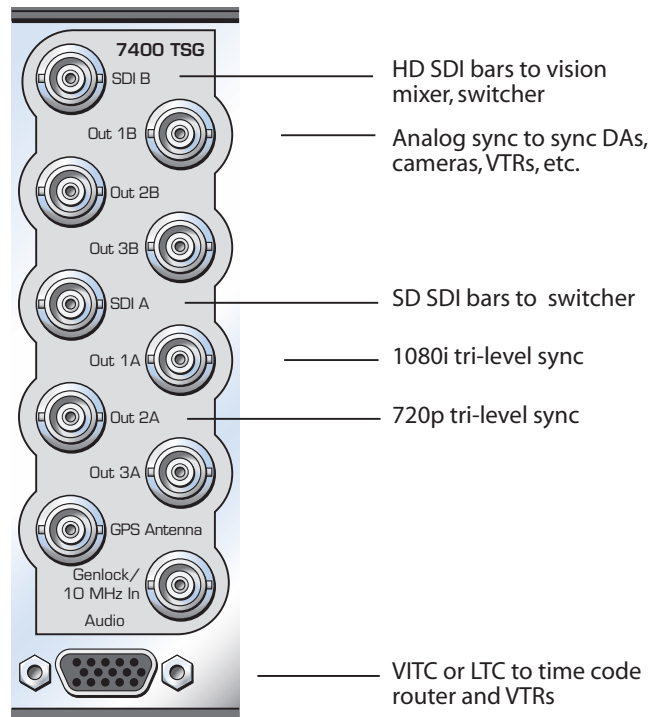

9400 Mobile Application Configuration Example

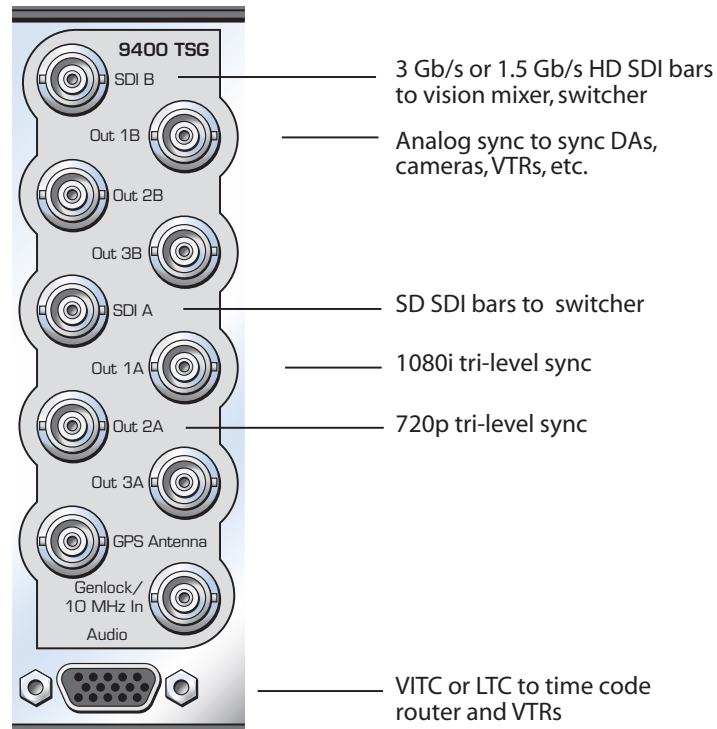

Post Production

Both Model 7400 and Model 9400 can output multiple formats of Tri-Level Sync at the same time, fitting the requirements of busy post production houses. At the same time, the 7400 or 9400 will output HD-SDI test signals (1.5 Gb/s for the 7400, and 3 Gb/s and 1.5 Gb/s for the 9400), SD SDI and composite test signals, and color black reference. All of these video outputs are derived from the same time base and can be timed with respect to each other. Models 7400 and 9400 can simultaneously deliver both 525 (NTSC) and 625 (PAL) based signals.

Models 7400 and 9400 provide extensive support for analog and digital audio. Because all of the video outputs can be locked to a common time base, the AES digital audio outputs are always synchronous with all of the video outputs - regardless of format. Multiple tone generators make it easy to identify multi-channel content.

Multiple time code generators, another feature of the 7400 and 9400, work very well for post. Time code is delivered as LTC (both 75 Ohm BNC and 110 Ohm Balanced), VITC, and DVITC. One generator can be configured to produce 525/59.94 drop frame time code while the other generator is making 1080sF/23.98.

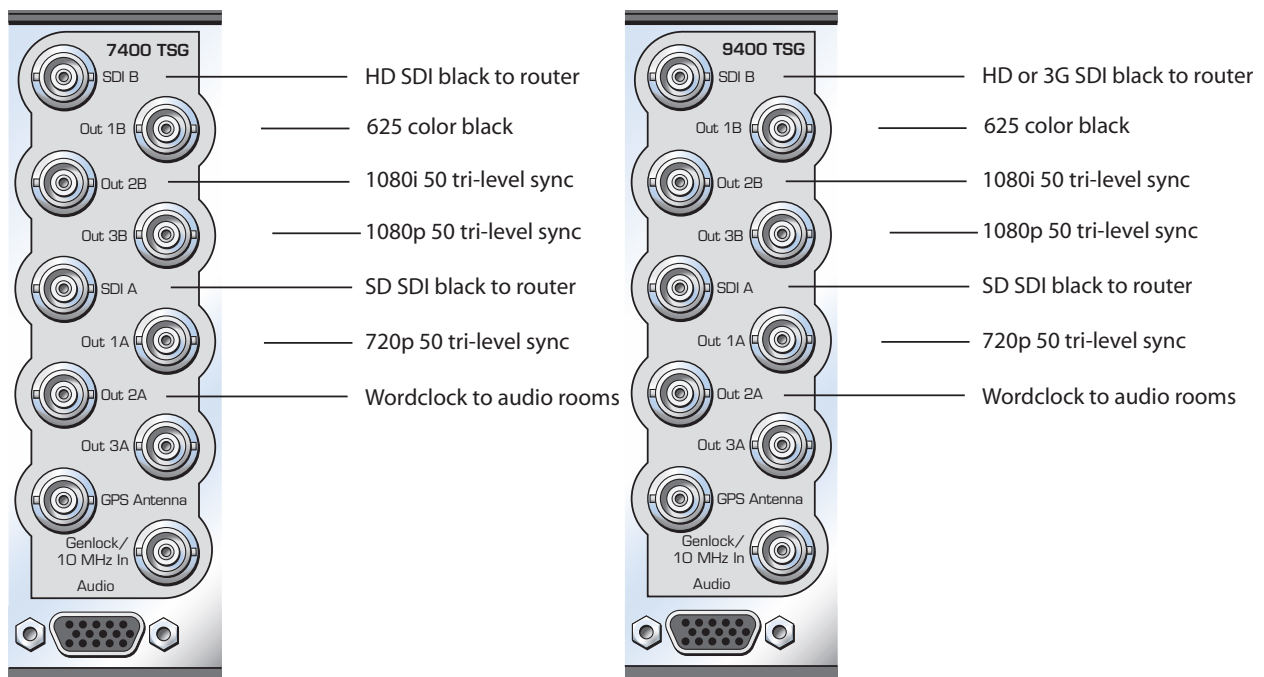

7400 Post House Configuration Example

9400 Post House Configuration Example

Custom Test Patterns

Using the Secure Digital Card slot on the front of the 7400 or 9400, users can load custom test patterns and video slates into the module. With simultaneous audio and video playback, you can have branded color bars available everywhere in the facility.

Timecode

How the Timecode is Generated

Each of the two (independent) SPG/TSGs on a 7400 or 9400 module has its own timecode generator. The timecode generator will always run at the same frame rate as the SDI output of that SPG/TSG.

SDI Output	TC Frame Rate	VITC on SD Output	Drop
720p/59.94	29.97 Frames/second*	yes	On or Off
720p/50	25 Frames/second*	yes	N/A
1080i/59.94	29.97 Frames/second	yes	On or Off
1080i/50	25 Frames/second	yes	N/A
1080sF/23.98	23.98 Frames/second	no	On or Off
1080sF/24	24 Frames/second	no	N/A
SD 525	29.97 Frames/second	yes	On or Off
SD 625	25 Frames/second	yes	N/A

*In these two cases, timecode identifies pairs of video frames, with field bit used to identify first and second frames of each pair. This is because the legacy SMPTE 12M specification cannot accommodate frame rates larger than 39Hz.

The user can "Jam" a specific time setting into the timecode generator. If the GPS option is installed, the Timecode generator can be commanded to pick up current time of day. The Timecode generator can be configured for drop or non-drop operation when running in the NTSC related frame rates.

Analog Timecode

There are four ways to have analog timecode, described as follows:

1. Route LTC (linear timecode) to user-programmable BNC 2 or 3. The signal will be 1 V P-P, unbalanced (i.e., single ended). This is an analog timecode signal. Many devices want timecode on a BNC.
2. Select LTC to appear as one of the module's analog audio output signals. This will be exactly the same signal as when it is routed to a BNC, but it will be a balanced analog signal. It would appear on the HD-15 connector as one of the four balanced audio outputs.
3. LTC can be selected as one of the audio signals to be embedded in the SDI output stream.
4. LTC can be selected as one of the audio signals to be output as AES on User Pgm Outputs 2 or 3.

You can output an analog timecode signal with any of the methods described above. The difference between them is a choice between balanced or unbalanced. If you need to feed timecode to a device with an XLR input, you would generally want to use the balanced output. However, it is also possible to use the unbalanced through user-programmable BNC output and connect it to the destination with a balancing transformer. This would be much like the DATS adaptors for AES.

The advantage of using the unbalanced BNC output is that you can run it through a 5150 Distribution Amplifier to make more copies.

Vertical Interval Timecode (VITC) and Digital Vertical Interval Timecode (DVITC)

The 7400 and 9400 offer the following ways to have Vertical Interval Timecode (VITC) and Digital Vertical Interval Timecode (DVITC):

1. The Analog Composite output of each generator (User-Programmable Output 1) can have VITC carried in the vertical interval.
2. When the SDI output is standard definition, it can have VITC in the vertical interval. This is basically a digitized version of the VITC that would be in an analog composite signal.
3. When the SDI output is high definition, it can have DVITC packets carried in the ancillary data spaces.
4. When a 7400 GPS option is installed, VITC and DVITC are available from the GPS.

Locking to a Black Burst Signal with VITC

Models 7400 and 9400 can lock to a black burst signal which has VITC in it. In that case, the timecode generator in the 7400 or 9400 will track that VITC reference.

Audio Generation and Routing

Audio Generators

The diagram shown below depicts the audio signal generation and routing for a single SPG/TSG Generator. There are two generators on each 7400 or 9400, Generator A and Generator B. Each of the two generators on the module are identical, with completely independent controls.

Support for Analog and Digital Audio

The AES digital audio outputs are always synchronous with all of the video outputs – regardless of format – because all of the video outputs can be locked to a common time base. Multiple tone generators can be used to identify multi-channel content.

Sixteen Independently Programmable Audio Channels Per Generator

Each generator supports sixteen audio channels and the content of each channel is independently programmable. Choices include adjustable frequency tone generators, tone sweeps, silence, timecode, audio clip playback from the 7400 or 9400's secure digital card, and the external AES input. Left/Right channel ID that synchronizes to the cyclops feature can also be selected.

Audio Embedded in the SDI Outputs

All sixteen of these channels can be embedded in the SDI outputs. Each AES output can select from any of the eight pairs that make up these sixteen channels. Similarly, the stereo analog output of each generator can be driven from any of these audio signal pairs.

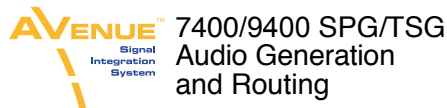

This drawing depicts the Audio Signal Generation and routing for a single SPG/TSG Generator. Each of the two generators on the 7400 and 9400 are identical, with completely independent controls.

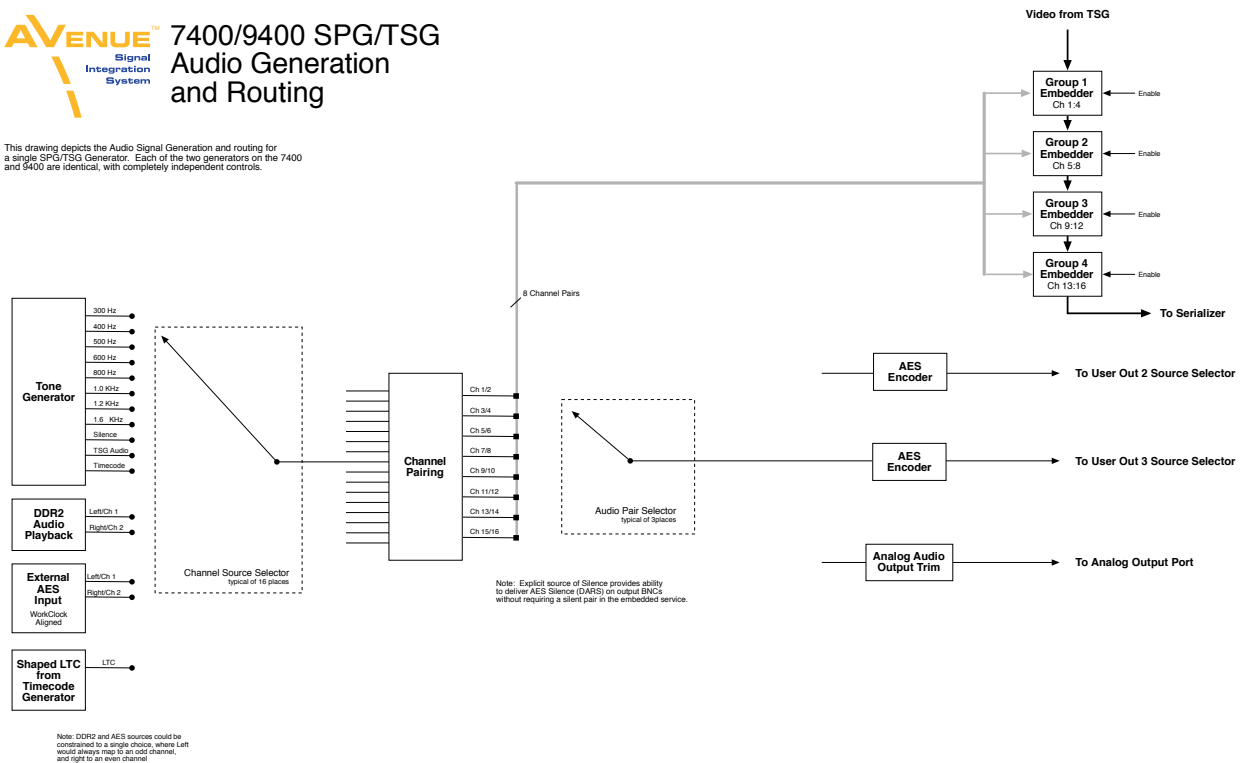

Note: Explicit source of Silence provides ability to deliver AES Silence (DMS) on output DMCS without requiring a silent pair in the embedded service.

Note: DDR2 and AES sources could be constrained to a single choice, where Left would always map to an odd channel, and right to an even channel

7400 and 9400 Audio Generation and Routing Diagram, portrait view

AVENUE™ Signal Integration System
7400/9400 SPG/TSG
Audio Generation and Routing

This drawing depicts the Audio Signal Generation and routing for a single SPG/TSG Generator. Each of the two generators on the 7400 and 9400 are identical, with completely independent controls.

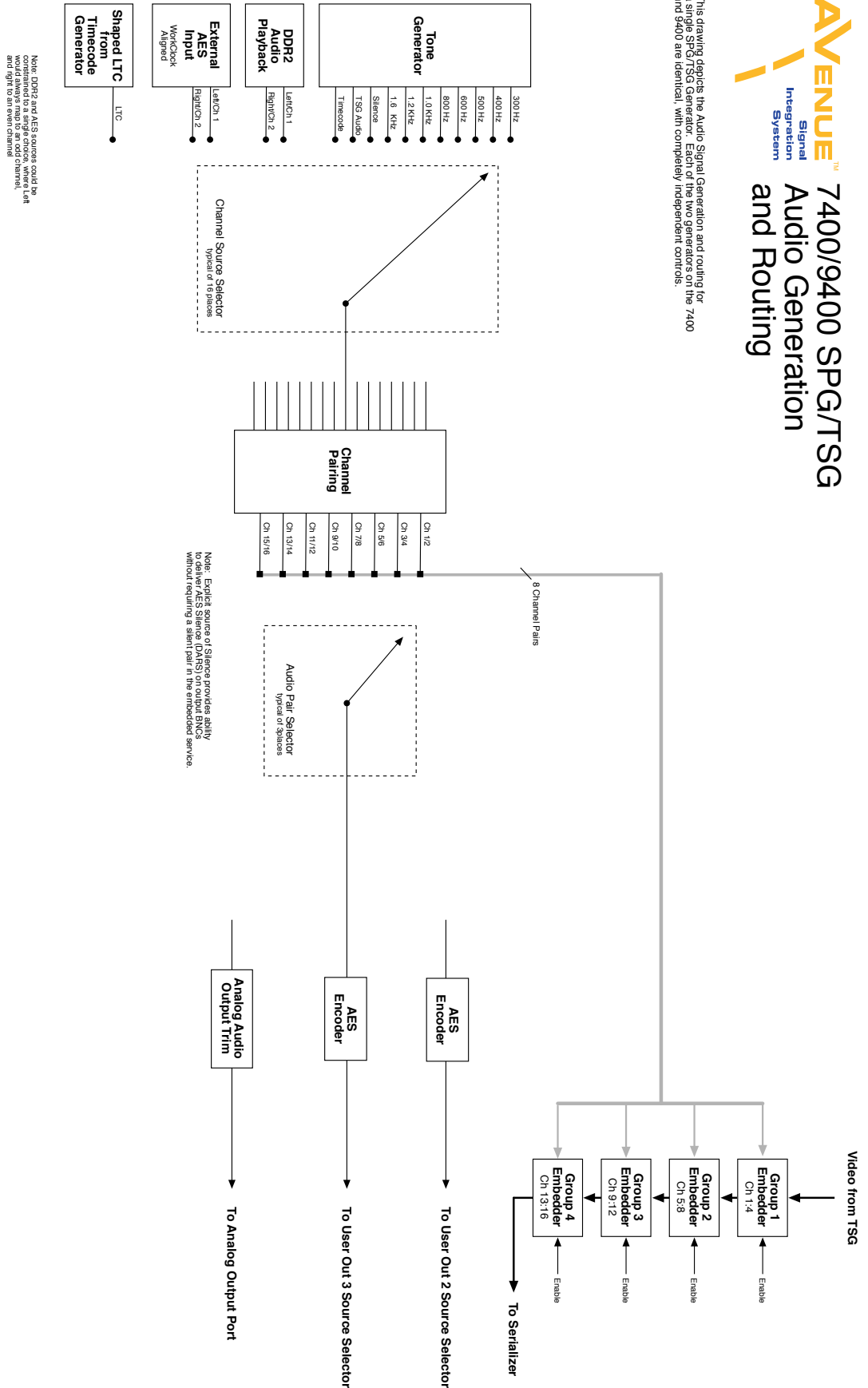

Note: DDR2 and AES sources could be used in any combination. Left and right would average map to an odd channel and right to an even channel.

Note: Explicit source of Silence provides ability to deliver AES Silence (DARS) on output BNCs without requiring a silent pair in the embedded service.

7400 and 9400 Audio Generation and Routing Diagram, Landscape view

Installation

Plug the 7400 or 9400 module into any one of the slots in the 3RU frame. In a 1RU frame, 7400 and 9400 modules can be installed in slots 1 or 2, and not in slot 3. Install the plastic overlay provided onto the corresponding group of rear BNC connectors associated with the module location. Note that the plastic overlay has an optional adhesive backing for securing it to the frame. Use of the adhesive backing is only necessary if you would like the location to be permanent and is not recommended if you need to change module locations. This module may be hot-swapped (inserted or removed) without powering down or disturbing performance of the other modules in the system.

7400-GPS Option Field Installation Procedure

The 7400-GPS Option seamlessly integrates into the Avenue system by plugging directly onto a 7400 or 9400 module. It can be easily installed in the field. The 7400-GPS Option consists of a compact, weatherproof antenna (with internal high-gain pre-amp) and a receiver submodule which mounts directly to the 7400 or 9400 module. The included GPS antenna mounts onto standard 3/4" threaded pipe, metal or plastic. Connection from the F-style coaxial fitting on the antenna to the appropriate BNC on the Avenue Frame can be made with customer supplied standard 75 ohm cable. The coax cable can be routed through the center of the pipe for a completely waterproof installation. When low loss cable such as Belden 1694A is used, the antenna can be placed up to 200 feet (60 meters) from the frame. Ideally, the antenna is mounted outdoors where it has an unobstructed view of the sky.

If you order the 7400-GPS Option and Model 7400 or 9400 at the same time, we will install the 7400-GPS Option on to the main module at the factory. If you order the 7400-GPS Option and already have Model 7400 or 9400, you will receive the following kit.

7400-GPS Option Kit

The 7400-GPS Option consists of the following components, see photograph below:

- GPS Option submodule
- Three coaxial jumper cables
- GPS Compact Weatherproof Antenna with internal high-gain pre-amp (not shown in photo)
- Power and Control cable
- Four Phillips machine screws

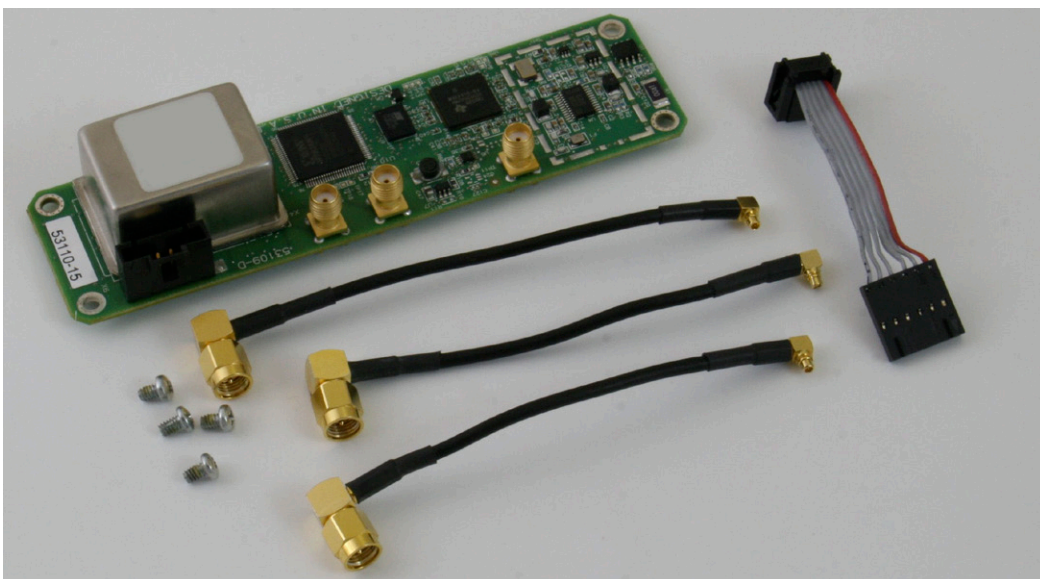

Securing the 7400-GPS Option Submodule to the 7400 or 9400 Main Module

Mount the 7400-GPS Option submodule onto the backside of the 7400 or 9400 main module and secure it using the four Phillips machine screws provided in your kit.

The first photo below shows the 7400 or 9400 main module prior to installing the optional 7400-GPS Option submodule. This is a topside view. Note the large hole in the module that the 7400-GPS Option submodule protrudes through when installed.

The second photo shows the bottom side of the 7400 or 9400 main module with the 7400-GPS Option submodule installed and retained with the four machine screws.

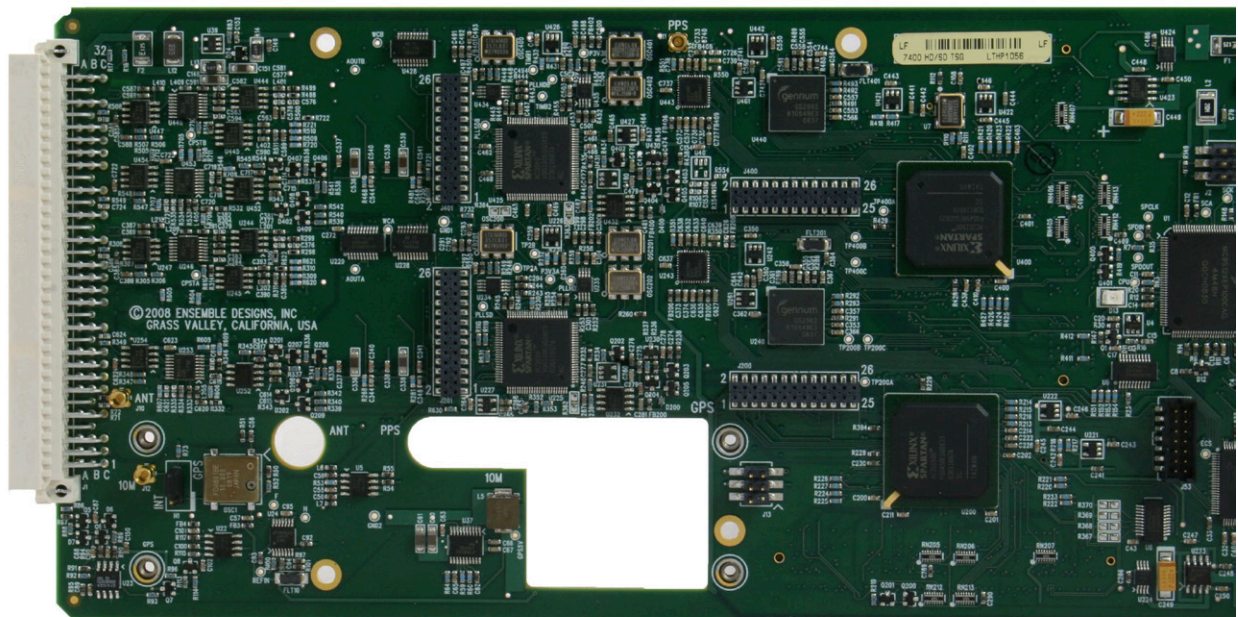

7400 or 9400 module prior to 7400-GPS Option installation, top side view

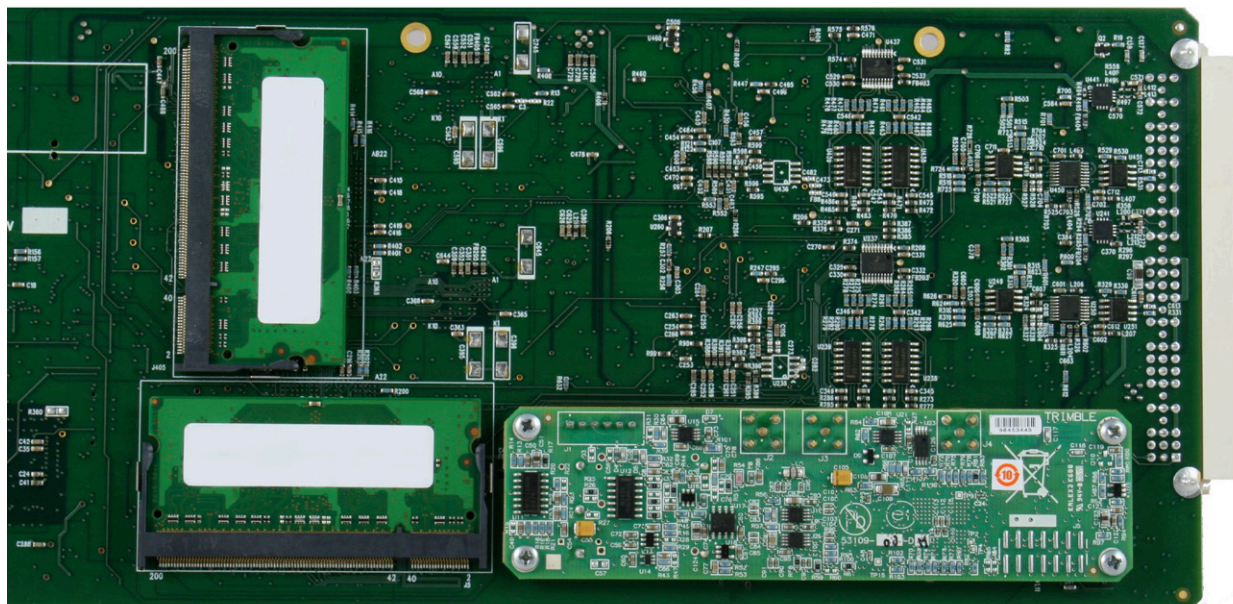

7400 or 9400 module with 7400-GPS Option installed, bottom side view

Connecting the Cables between the 7400-GPS Option Submodule and the 7400 or 9400 Main Module

Connect the three coaxial cables as shown in the photo below. Note that for each of these cables the main module and the submodule have matching labels:

- 10M submodule connects to 10M main module
- ANT submodule connects to ANT main module
- PPS submodule connects to PPS main module

Connect the power/control cable as shown in the photo below. Note how the ribbon cable connects, and the orientation of the red band which indicates pin 1.

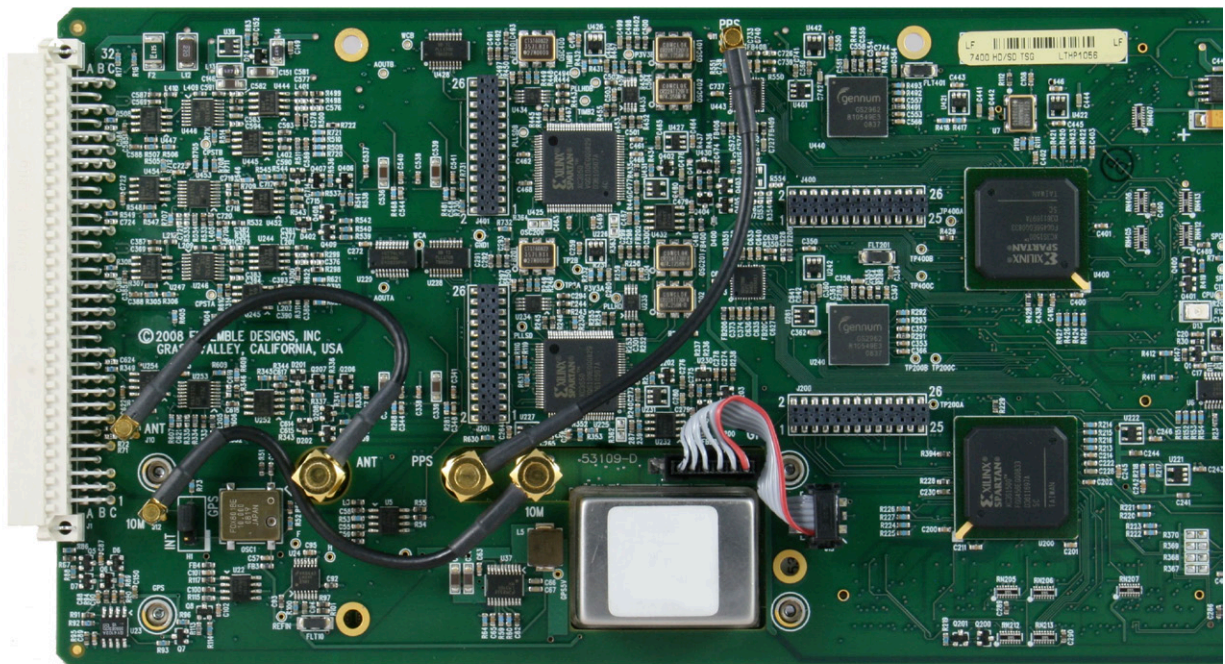

7400-GPS Option cabling detail

Installing the GPS Antenna

The included GPS antenna is compact, weatherproof, and has internal high-gain pre-amplification. It mounts onto standard 3/4" threaded pipe, metal or plastic. Connection from the F-style coaxial fitting on the antenna to the appropriate BNC on the Avenue Frame can be made with customer supplied standard 75 ohm cable. The coax cable can be routed through the center of the pipe for a completely waterproof installation. When low loss cable such as Belden 1694A is used, the antenna can be placed up to 200 feet (60 meters) from the frame. Ideally, the antenna is mounted outdoors where it has an unobstructed view of the sky.

Even if you do not connect the GPS Antenna to the 7400-GPS module, it will nevertheless provide greater accuracy than the module's internal TCXO (Temperature Compensated Crystal Oscillator).

Safety and Outdoor Antenna Grounding

When installing the antenna for the 7400-GPS option, please be aware of safety precautions with respect to outdoor antenna grounding. Please read the following excerpt from the National Electric Code and refer to the below illustration.

"If an outside antenna or cable system is connected to the product, be sure the antenna or cable system is grounded so as to provide some protection against voltage surges and built-up static charges. Article 810 of the National Electrical Code, ANSI/NFPA 70, provides information with regard to proper grounding of the mast and supporting structure, grounding of the lead-in wire to an antenna discharge unit, size of grounding conductors, location of antenna-discharge unit, connection to grounding electrodes, and requirements for the grounding electrode."

Example of antenna grounding as per National Electrical Code, ANSI/NFPA 70

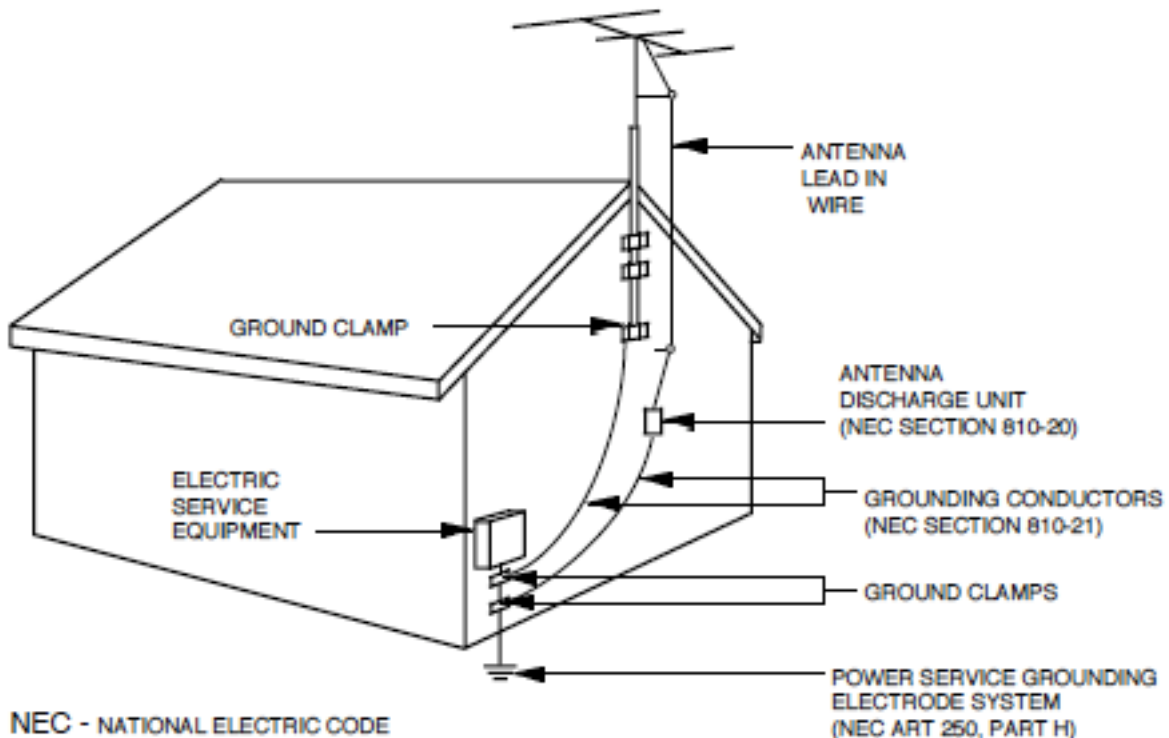

Cabling

Refer to the 3RU and 1RU backplane diagrams of the module below for cabling instructions. Note that unless stated otherwise, the 1RU cabling explanations are identical to those given in the 3RU diagram.

Outputs HD or SD test signals (plus 3G for 9400). Select frame rate family for all of Generator B; 59.94, 50 or 60. Output can include 16 channels of embedded audio – tone, silence or external audio. Can also include DVITC.

Outputs one of the following: Tri-Level Sync from TLS Gen 2 (can be different from Out 1 B) LTC, AES (any of 8 pairs), AES silence, Word clock, 6 Hz pulse, 10 MHz (only if locked to internal or GPS reference).

Outputs HD or SD test signals (plus 3G for 9400). Select frame rate family for all of Generator A; 59.94, 50 or 60. Output can include 16 channels of embedded audio – tone, silence or external audio. Can also include DVITC.

Outputs one of the following: Tri-Level Sync from TLS Gen 2 (can be different from Out 1 A) LTC, AES (any of 8 pairs), AES silence, Word clock, 6 Hz pulse, 10 MHz (only if locked to internal or GPS reference).

Stereo audio output.

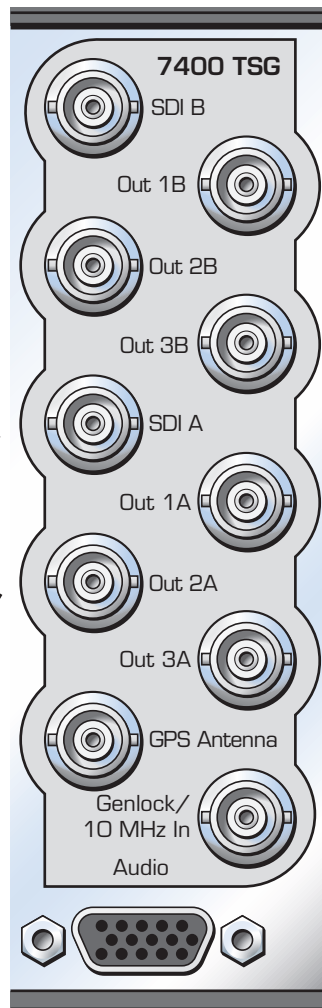

Outputs analog composite black, composite 100% bars, or Tri-Level Sync from TLS Gen 1. When SDI Out B is a SD test pattern, this BNC can also output a composite version of that test pattern. Composite output can include VITC.

Outputs one of the following: Tri-Level Sync from TLS Gen 2 (same as Out 2 B), LTC, AES (any of 8 pairs), AES silence, Word clock, 6 Hz pulse, 10 MHz (only if locked to internal or GPS reference).

Outputs analog composite black, composite 100% bars, or Tri-Level Sync from TLS Gen 1. When SDI Out A is a SD test pattern, this BNC can also output a composite version of that test pattern. Composite output can include VITC.

Outputs one of the following: Tri-Level Sync from TLS Gen 2 (same as Out 2 A), LTC, AES (any of 8 pairs), AES silence, Word clock, 6 Hz pulse, 10 MHz (only if locked to internal or GPS reference).

3RU Backplane for 7400

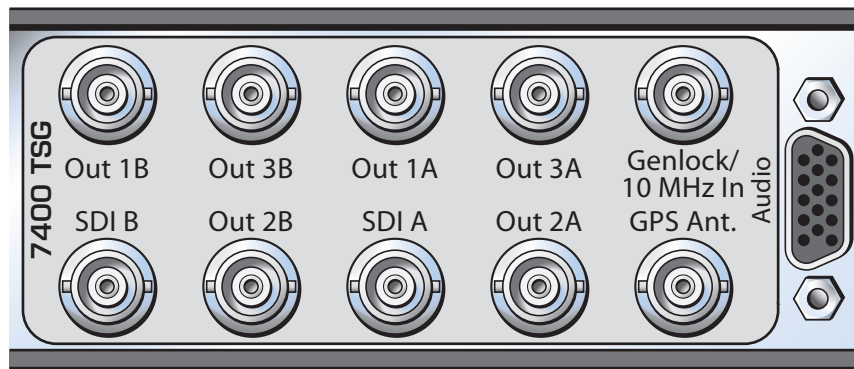

1RU Backplane for 7400

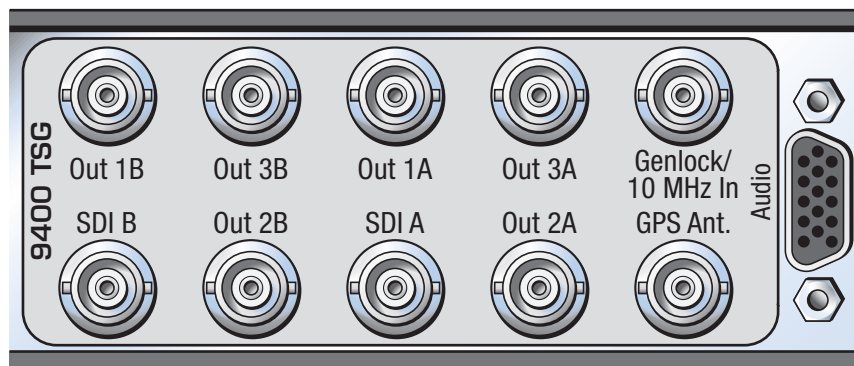

1RU Backplane for 9400

You can access four mono channels of audio analog tone outputs as shown in the pinout below. Channels 1 and 2 come from Audio Generator A; Channels 3 and 4 come from Audio Generator B. Channels 1 through 4 can be assigned to any of the 16 channels of audio from the Aud Gen A/B menu pages.

AUD 1 is on pins 1 and 2 and the associated ground is pin 7. Pin 1 is positive. AUD 2 is on pins 4 and 5 and the associated ground is pin 8. Pin 5 is positive.

AUD 3 is on pins 11 and 12 and the associated ground is pin 9. Pin 11 is positive. AUD 4 is on pins 14 and 15 and the associated ground is pin 10. Pin 15 is positive.

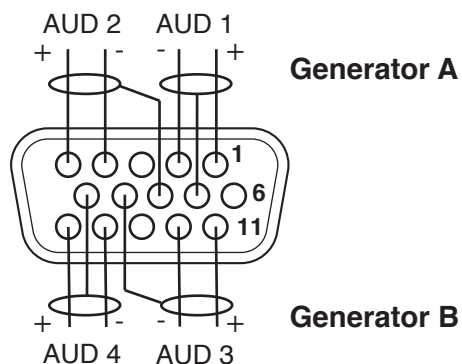

Generator A

- **SDI Out A** – Outputs HD or SD test signals (plus 3G for 9400). Select frame rate family for all of **Generator A**; 59.94, 50 or 60. Output can include 16 channels of embedded audio. The embedded audio can be any combination of the following: tone, silence, external audio. Can also include DVITC.
- **Programmable Out 1 A** – Outputs analog composite black, composite 100% bars, or Tri-Level Sync from TLS Gen 1. When SDI Out A is a SD test pattern, this BNC can also output a composite version of that test pattern. Composite output can include VITC.
- **Programmable Out 2 A** – Outputs one of the following: Tri-Level Sync from TLS Gen 2 (can be different from Out 1 A), LTC, AES (any of 8 pairs), AES silence, Word clock, 6 Hz pulse, 10 MHz (only if locked to internal or GPS reference).
- **Programmable Out 3 A** – Outputs one of the following: Tri-Level Sync from TLS Gen 2 (same as Out 2 A), LTC, AES (any of 8 pairs), AES silence, Word clock, 6 Hz pulse, 10 MHz (only if locked to internal or GPS reference).

Note: Generator A has two independent Tri-Level Sync generators; TLS Gen 1 and TLS Gen 2. The output from TLS Gen 1 is available on BNC Out 1 A. The output from TLS Gen 2 is available on BNC's Out 2 A and Out 3 A. Refer to the "Functional Block Diagram" on page 8 for more information.

- **Analog Audio** - stereo output, 1 of 8 pairs from the audio generator.

Generator B

Has the same outputs as noted for **Generator A**. **Generator B** is completely independent from **Generator A**. **Generator B** can operate in a different frame rate family and its set of outputs can be timed independently.

Module Configuration and Control

Avenue module parameters can be configured and controlled remotely from one or both of the remote control options: the Avenue Touch Screen or the Avenue PC Application. Once the module parameters have been set remotely, the information is stored on the module CPU. This allows the module be moved to a different slot in the frame at your discretion without losing the stored information.

Details for setting module parameters remotely using the Avenue PC option or the Avenue Touch Screen option are described and illustrated in the "Avenue PC and Touch Screen Remote Configuration" section of this manual.

Front Panel Controls and Indicators

Each front edge indicator is shown in the diagram below:

Ref SD, HD and 10 MHz

green LEDs:

One LED will light to indicate which type of reference is currently being detected. If no LED is lit, no reference is detected.

Generator A SD/HD

green LEDs:

One LED will light to indicate the Primary output standard and that it is locked to its timing source. If no LED is lit, the Primary generator is not locked to its timing source.

Run green LED:

OFF: A power fault or halted CPU

ON: A halted CPU

FAST BLINK: CPU Run error

SLOW BLINK: System OK (If SPI control is active from the main frame System Control Module, all module **Run** indicators will be synchronized.)

Pwr green LED:

Indicates the presence (**ON**) or absence (**OFF**) of power (+5V).

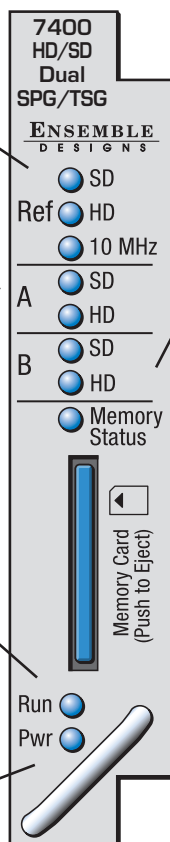

Generator B SD/HD

green LEDs:

One LED will light to indicate the Primary output standard and that it is locked to its timing source. If no LED is lit, the Primary generator is not locked to its timing source.

Memory Status green LED:

LED flashes when memory is being accessed. Illuminates green when memory is available.

Avenue PC and Touch Screen Remote Configuration

The Avenue PC and Touch Screen remote control menus for this module are illustrated and explained in this section. Refer to each menu's description in the following pages for a summary of available parameters that can be set remotely through the menus illustrated. Both the Avenue PC and Touch Screen user interfaces are shown for your reference. For more information on using Avenue PC, refer to the Avenue PC Control Application Software manual.

Parameter fields that are grayed out can indicate one of the following conditions:

- An option is not installed.
- The function is not active.
- The module is locked.
- The User Level set with Avenue PC does not permit access.

7400 and 9400 Avenue PC and Touch Screen Menus

Sync Pulse Generator A Menu

Selecting the Reference Source and Output Standard for Sync Pulse Generator A

The **SPG A** menu controls the **SDI Out A** BNC. The standard selected determines what signal will be output on the **SDI Out A** BNC.

Important: Additionally, the standard selected in the **SPG A** menu determines the frame rate family for all of the **Generator A** BNC outputs (**SDI Out A**, **Out 1 A**, **Out 2 A**, **Out 3 A**). For example, if the standard is set to SD 525 or 720p/59.94, then all **Generator A** outputs will be in the 59.94 Hz frame rate family. If the standard is set to SD 625 or 1080i/50, then all **Generator A** outputs will be in the 50 Hz frame rate family.

To select the reference source and output standard of **Sync Pulse Generator A**, select the **SPG A** menu shown below. Set the parameters for the **Source** and **Standard** fields. The standard that the module is locked to is shown in the **Sync Lock** field. Use the controls to set the following:

- **Source** – select the reference source for **Generator A**. Select from:
 - Internal/GPS** – the module's Internal Precision Standard reference signal, or the signal from the GPS Receiver (with 7400-GPS Option installed). If the GPS signal is present, the 7400 will lock to that. If the GPS signal is not present, the 7400 will lock to its internal TCXO.
 - Config Ref** – locks to the source selected as the **Config Ref** in the **Global** menu. If you choose **Config Ref**, you must have configured that parameter in the **Global** menu. *See the "Global Menu" on page 61 for more information.*
 - Other Gen** – locks to the reference of **Generator B**.
- **Sync Lock** – reports what standard the module is locked to.

Note: If you are using the 7400-GPS option, be sure the H1 jumper on the main module is installed in the GPS position to lock to the GPS reference signal. If the H1 jumper is installed in the INT position it locks to the 7400 or 9400's internal TCXO (Temperature Compensated Crystal Oscillator). *See the "7400-GPS Option Field Installation Procedure" on page 17 for more information.*

- **Standard** – select the output standard you want from the following:

720p/50	1080p/23.98
720p/59.94	1080p/24
720p/60	1080sF/25
1080i/50	1080sF/23.98
1080i/59.94	1080sF/24
1080i/60	SD 525
1080p/25	SD 625

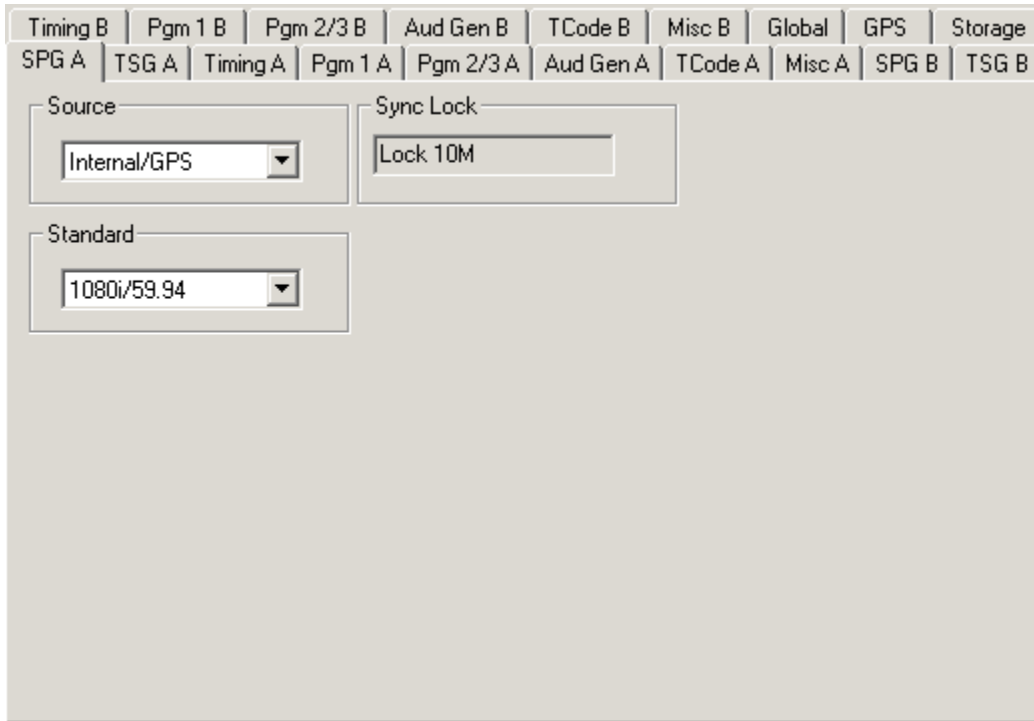

SPG A Avenue PC Menu

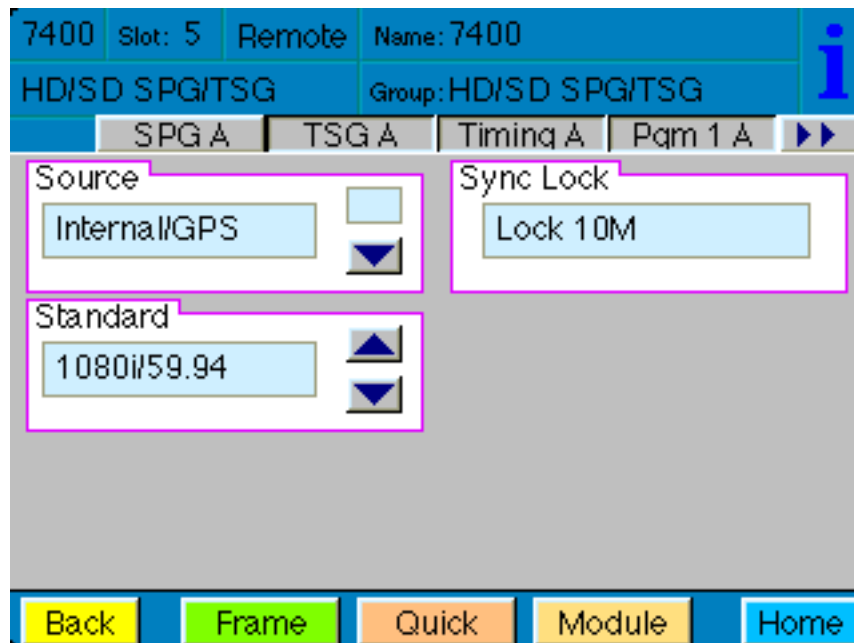

SPG A Touch Screen Menu

Test Signal Generator A Menu

Selecting the Pattern Type, Output Standard and Y, Cr and Cb Channels for Test Signal Generator A

The **TSG A** menu affects the **SDI Out A** BNC. It also affects the **Out 1 A** BNC if it has been set to "Follow SDI."

To set the type of test pattern for the output of **Test Signal Generator A**, select the **TSG A** menu shown below. This menu also has controls for turning on and off the Y, Cr and Cb channels. Use the controls to set the following:

- **Pattern Type** – Select the pattern group in the first drop-down menu and the test signal in the second drop-down menu.

Pattern Group	Test Signal
Bars	Full Field 75 Full Field 100 SMPTE 75 Split Field 75 Split Field 100 Red Field RGB444 Bars A RGB444 Bars B
Black	Black Flat Field 20 Flat Field 50 Flat Field 80 White RGB444 Black
Ramp	Video Ramp Data Ramp Shallow 5 Step
Sweep	Sweep MultiBurst
Pulse & Bar	Full Field Window Component
Timing	Digital Blanking Cosite Interlace
Misc	Black Crosshatch Safe Title Pathological
Card	Custom Test Patterns from Secure Digital Card

- **Y Channel, Cr Channel, Cb Channel checkboxes** – There are independent enables for each channel so that Y, Cr and Cb can be controlled separately. You may choose to turn off the Y, Cr and/or Cb Channels if desired for test purposes (such as setting up a monitor). To turn off one or more channels, deselect the **Enabled** check box.
- **Number** – The selection available in this menu will reflect the number of custom test patterns loaded onto the SD storage card. A maximum of 255 user-created custom test patterns can be loaded.
- **Name** – Each of the up to 255 custom test patterns will have a name when loaded from the SD storage card. The name of the test pattern selected from the SD card will display in this field.

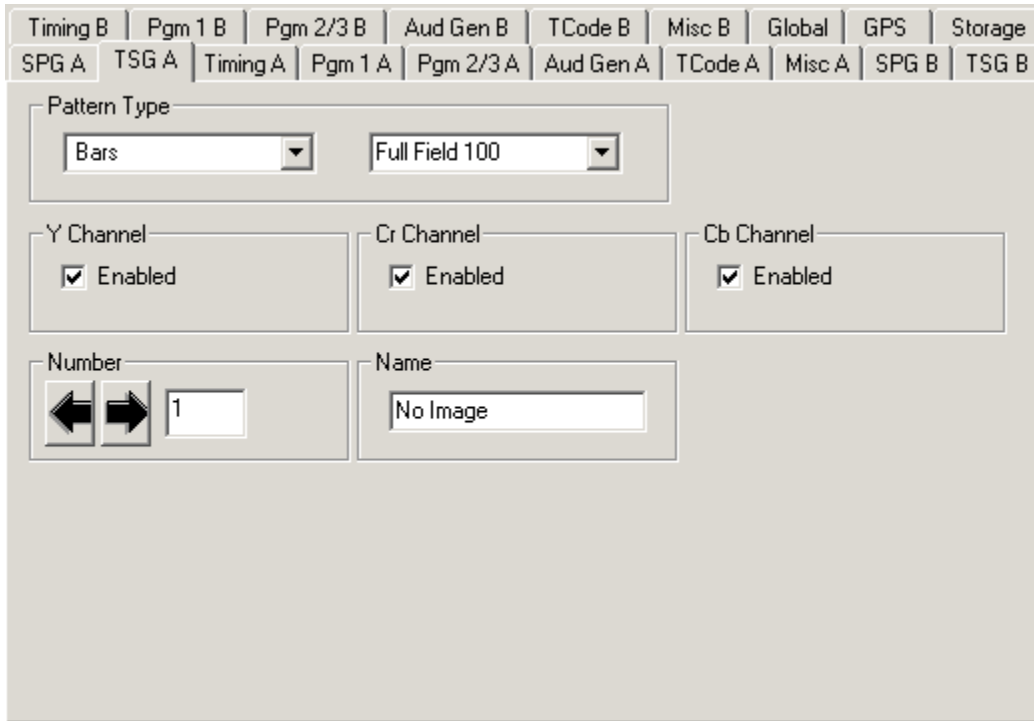

TSG A Avenue PC Menu

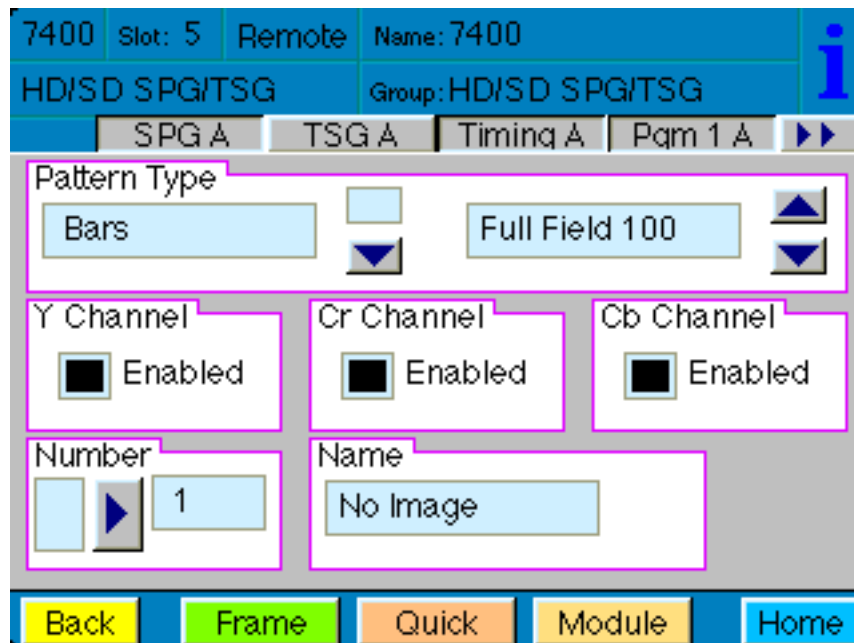

TSG A Touch Screen Menu

Timing A Menu

Setting the Vertical Timing, Horizontal Timing and Fine Phase for Generator A

The **Timing A** menu shown below allows you to set the timing of the **Generator A** outputs with respect to the reference selected in the **SPG A** menu. This menu affects the SDI output, the principal output of the generator, which applies to **SDI Out A** and **Programmable Output 1 A (Out 1 A BNC)**. Use the slider controls or arrows to select a value or enter a value into the number fields.

- **Vert Timing** – Set the vertical timing in lines. Range is -525 to 525, default is 0.
- **Hor Timing** – Set the horizontal timing in clocks. Range is -1716 to 1716, default is 0.
- **Fine Phase** – Set the fine phase of the Primary output in nanoseconds. Range is -35 to 35, default is 0.

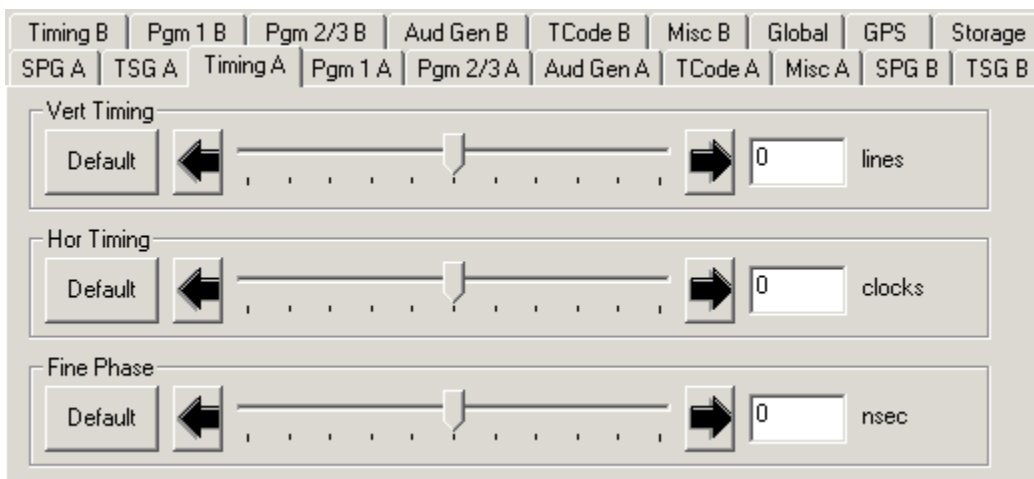

Timing A Avenue PC Menu

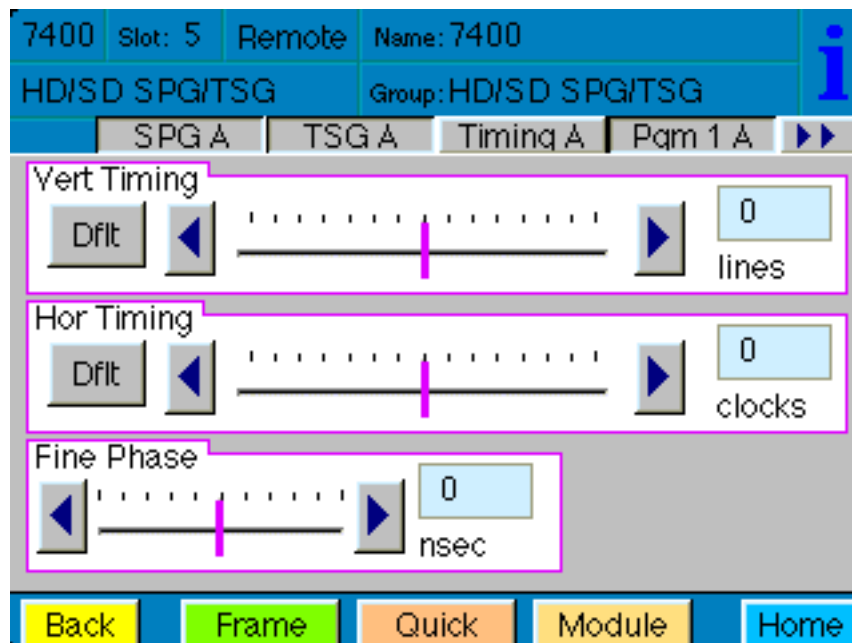

Timing A Touch Screen Menu

Programmable Output 1 A Menu

Setting the Output, Tri-Level Sync Output Standard, Fine Phase, Vertical Timing and Horizontal Timing for Programmable Output 1 A

The **Pgm 1 A** menu shown below allows you to set the **Programmable Output 1 A**, the Tri-Level Sync output standard, fine phase, vertical and horizontal timing. This menu affects the **Out 1 A** BNC.

Note: The selections you make from the **Pgm 1 OutSel** and **TLS Gen 1 Std** drop-down menus have to be from the same frame rate family as the standard selected in the **SPG A** menu.

Use the controls to set the following:

- **Pgm 1 OutSel** – Choose from:

- Black
- Color Bars
- Follow SDI Out
- TLS Gen 1

When “Follow SDI Out” is selected, the settings from the **TSG A** menu are being used.

- **TLS Gen 1 Std** – Choose an output standard from the following options:

- 720p/50
- 720p/59.94
- 720p/60
- 1080i/50
- 1080i/59.94
- 1080i/60
- 1080p/25
- 1080p/23.98
- 1080p/24
- 1080sF/25
- 1080sF/23.98
- 1080sF/24

Use the slider controls or arrows to select a value or enter a value into the number fields.

- **Fine Phase** – Set the fine phase of the output in nanoseconds. Range is -35 to 35, default is 0.
- **Vert Timing** – Set the vertical timing in lines. Range is -1000 to 1000, default is 0.
- **Hor Timing** – Set the horizontal timing in clocks. Range is -2000 to 2000, default is 0.

Note: If you select “Follow SDI Out” from the **Pgm 1 OutSel** drop-down menu, the **Fine Phase**, **Vert Timing** and **Hor Timing** controls will be grayed out and will not be usable.

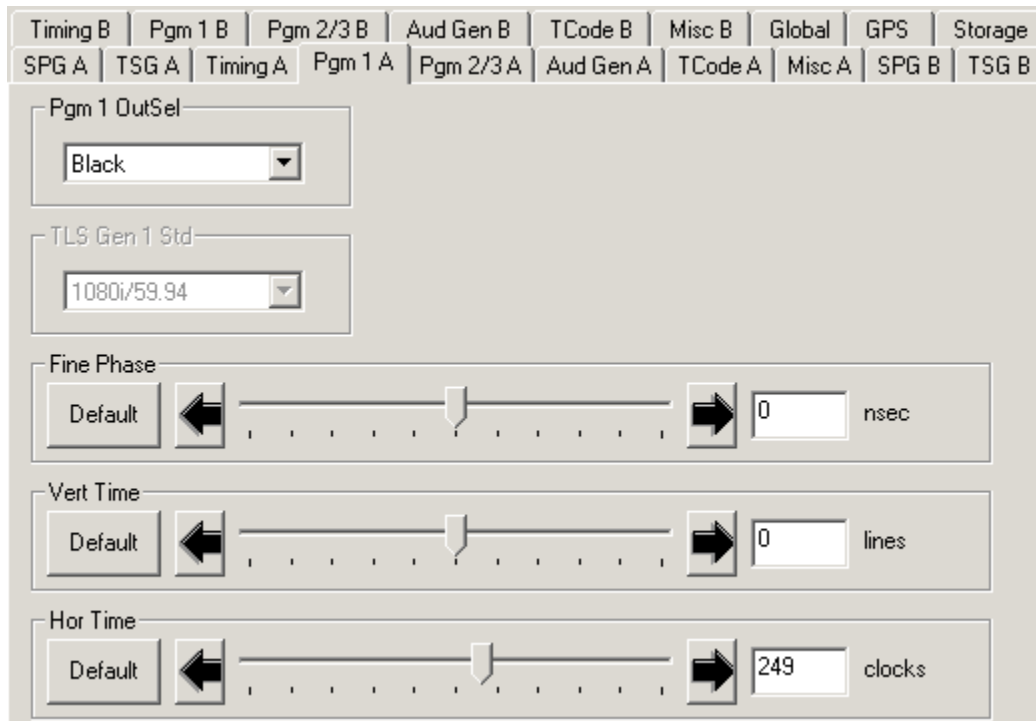

Pgm 1 A Avenue PC Menu

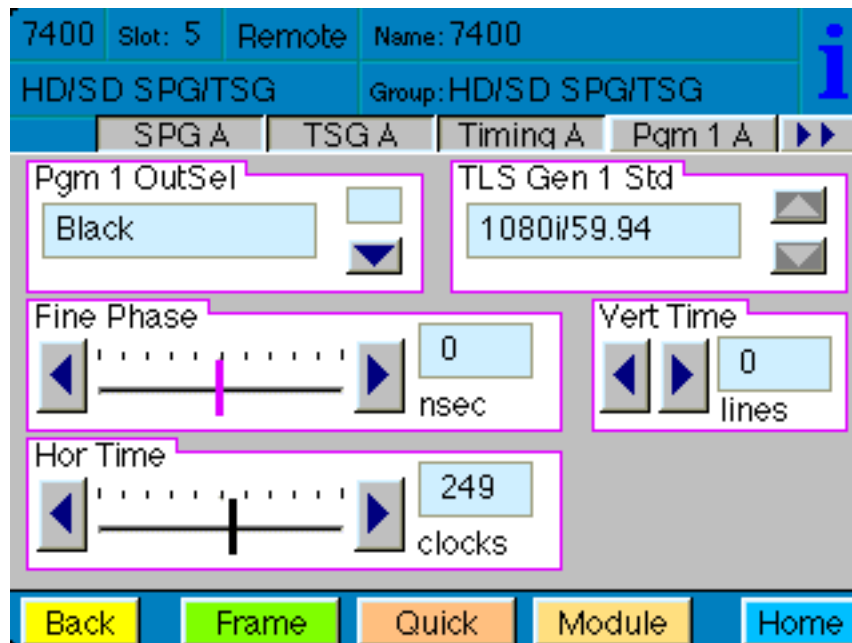

Pgm 1 A Touch Screen Menu

Programmable Outputs 2 A and 3 A Menu

Setting the Output, Tri-Level Sync Output Standard, Vertical Timing, and Horizontal Timing for Programmable Outputs 2 A and 3 A

The **Pgm 2/3 A** menu shown below allows you to set **Programmable Outputs 2 A and 3 A**, and the output standard, vertical timing and horizontal timing for Tri-Level Sync Generator 2. This menu affects the **Out 2 A** and **Out 3 A** BNCs.

Use the controls to set the following:

- **Pgm 2 OutSel** – Affects **Out 2 A** BNC. Choose from:

- TLS Gen 2
- LTC Timecode
- AES Audio 1/2
- AES Audio 3/4
- AES Audio 5/6
- AES Audio 7/8
- AES Audio 9/10
- AES Audio 11/12
- AES Audio 13/14
- AES Audio 15/16
- AES Silence
- Word Clock
- 6Hz Pulse
- 10MHz Clock

- **Pgm 3 OutSel** – Affects **Out 3 A** BNC. Choose from:

- TLS Gen 2
- LTC Timecode
- AES Audio 1/2
- AES Audio 3/4
- AES Audio 5/6
- AES Audio 7/8
- AES Audio 9/10
- AES Audio 11/12
- AES Audio 13/14
- AES Audio 15/16
- AES Silence
- Word Clock
- 6Hz Pulse
- 10MHz Clock

- **TLS Gen 2 Std** – Choose the output standard for Tri-Level Sync Generator 2. Choose from:

720p/50
720p/59.94
720p/60
1080i/50
1080i/59.94
1080i/60
1080p/25
1080p/23.98
1080p/24
1080sF/25
1080sF/23.98
1080sF/24

- **TLS 2 V Time** – Set the vertical timing in lines for **Tri-Level Sync Generator 2**. Range is -1000 to 1000, default is 0. Use the slider controls or arrows to select a value or enter a value into the number field.
- **TLS 2 H Time** – Set the horizontal timing in clocks for **Tri-Level Sync Generator 2**. Range is -2000 to 2000, default is 0. Use the slider controls or arrows to select a value or enter a value into the number field.

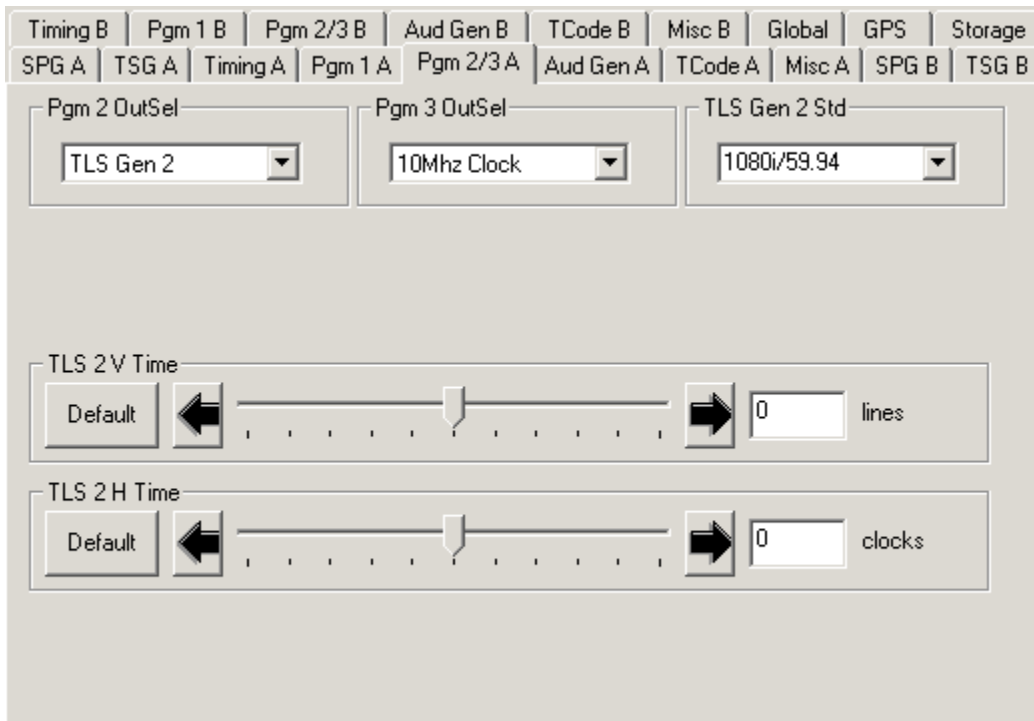

Pgm 2/3 A Avenue PC Menu

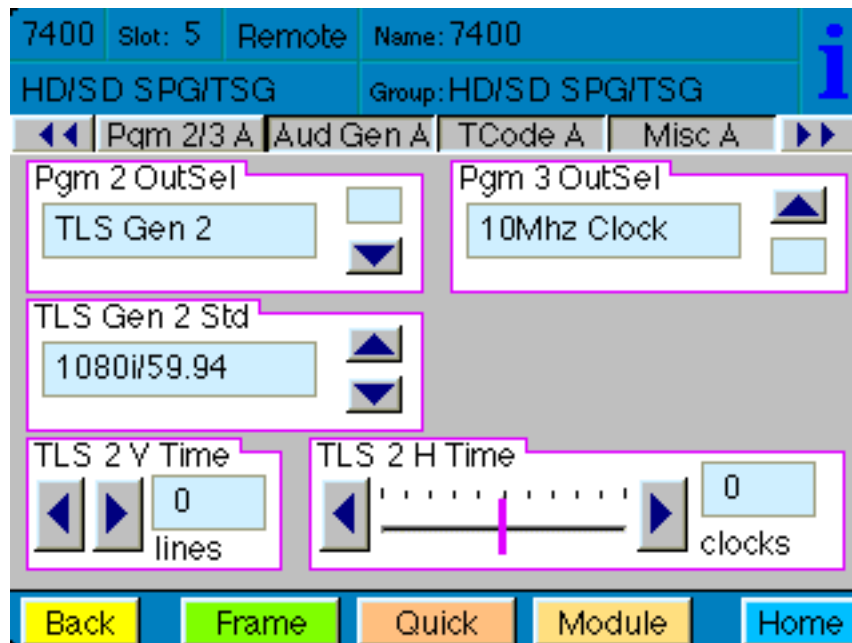

Pgm 2/3 A Touch Screen Menu

Audio Generator A Menu

Setting the Audio Generation and Routing Parameters for Audio Generator A

There are two generators on each 7400 or 9400, **Generator A** and **Generator B**. Each of the two generators are identical, with completely independent controls. The two AES digital audio outputs are always synchronous with all of the video outputs – regardless of format – because all of the video outputs can be locked to a common time base. Multiple tone generators can be used to identify multi-channel content. Each generator supports sixteen audio channels and the content of each channel is independently programmable. Choices include adjustable frequency tone generators, tone sweeps, silence, timecode, audio clip playback from the 7400's secure digital card, and the external AES input. All sixteen of these channels can be embedded in the SDI outputs. Each AES output can select from any of the eight pairs that make up these sixteen channels.

This menu affects the **Out 2 A** and **Out 3 A** BNCs.

There are three types of audio output:

- Embedded – audio embedded on the SDI output
- AES – goes to user-programmable output 2 (**Out 2 A**) and 3 (**Out 3 A**)
- Analog – output goes to **15-pin D connector**

The **Aud Gen A** menu shown below allows you to set the **Channel Number**, the **Audio Source**, to make Embedded Audio selections, and to choose the channel for **Analog Out**.

Use the controls to set the following:

- **Chan Number** – Available selections are 1 through 16
- **Audio Source** – Available selections are:
 - 300Hz Tone
 - 400Hz Tone
 - 500Hz Tone
 - 600Hz Tone
 - 800Hz Tone
 - 1.0KHz Tone
 - 1.2KHz Tone
 - 1.6KHz Tone
 - Silence
 - TSG Audio
 - Timecode
- **Embed Grp 1 through 4**
 - Group 1 includes channels 1/2 and 3/4
 - Group 2 includes channels 5/6 and 7/8
 - Group 3 includes channels 9/10 and 11/12
 - Group 4 includes channels 13/14 and 15/16

- **Analog Out** – Available selections are:

Channels 1/2
 Channels 3/4
 Channels 5/6
 Channels 7/8
 Channels 9/10
 Channels 11/12
 Channels 13/14
 Channels 15/16

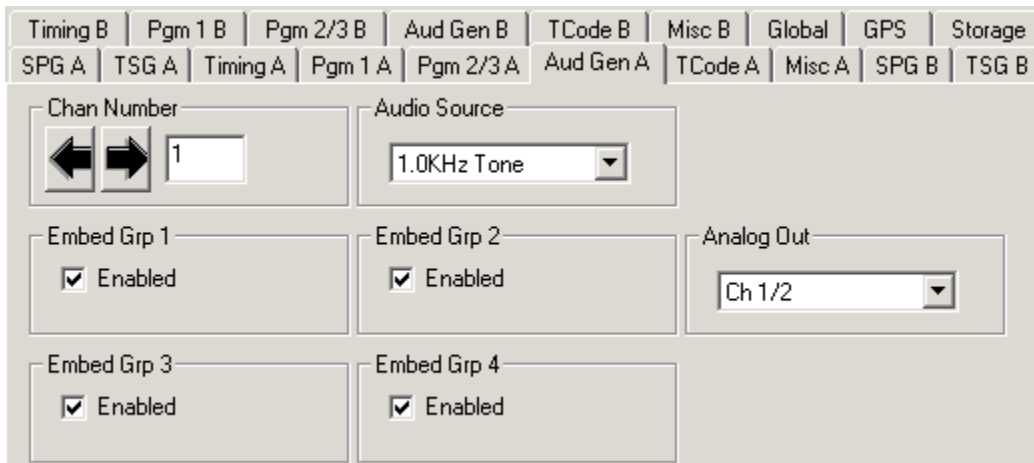

Aud Gen A Avenue PC Menu

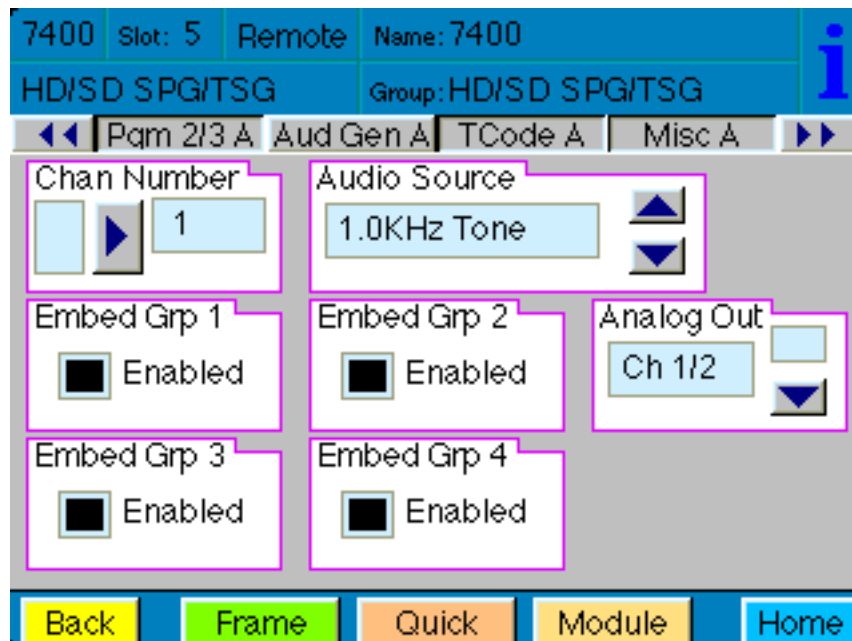

Aud Gen A Touch Screen Menu

Timecode A Menu

Setting the Timecode Parameters for Timecode A

The **TCode A** menu shown below provides controls to select your timecode source, manually set or offset timecode, insert VITC, and enable drop frame for Timecode Generator A.

TC Source – Available choices for timecode source are:

Manual/Jam – For entering a timecode manually.

GPS – For basing the timecode on the GPS source.

Ref VITC – For basing the timecode on the Reference vertical interval timecode.

Ref VITC w/ Offset – For basing the timecode on the Reference VITC, but offset by the amount of time entered manually in the Hours/Minutes/Seconds controls.

- **Manually set or offset the timecode** – These controls are used to manually enter the time in the **Manual/Jam** mode, and to manually offset the timecode when the timecode source is **Ref VITC with Offset**. These controls will be greyed out and will not be usable when the timecode source is **GPS**.

Hours – 0 through 23

Minutes – 0 through 59

Seconds – 0 through 59

- **VITC Insert** – Select from Off or one of the following a pair of lines: 13, 15; 14, 16; 15, 17; 16, 18; 17, 19; 18, 20; 19, 21.
- **Drop Frame** – Select the checkbox to enable Drop Frame (dropping two frames every minute except on every tenth minute) to allow timecode to match a real-time clock.
- **Jam!** – To manually enter the starting timecode value, enter the desired values in the **Hours**, **Minutes** and **Seconds** fields, then click the **Jam!** button.

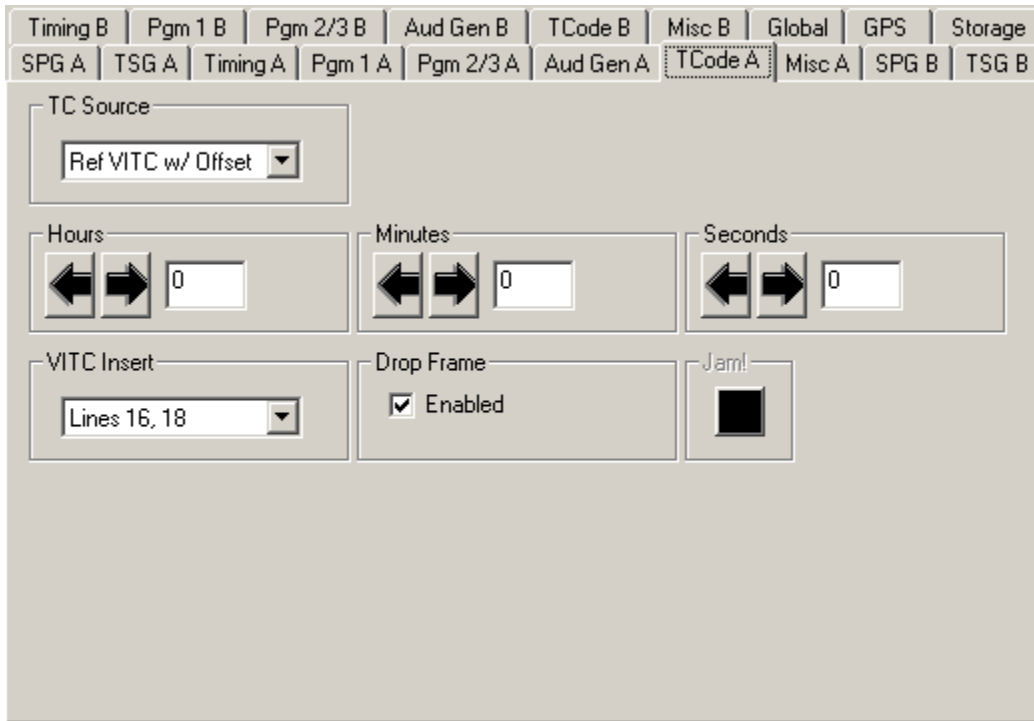

TCode A Avenue PC Menu

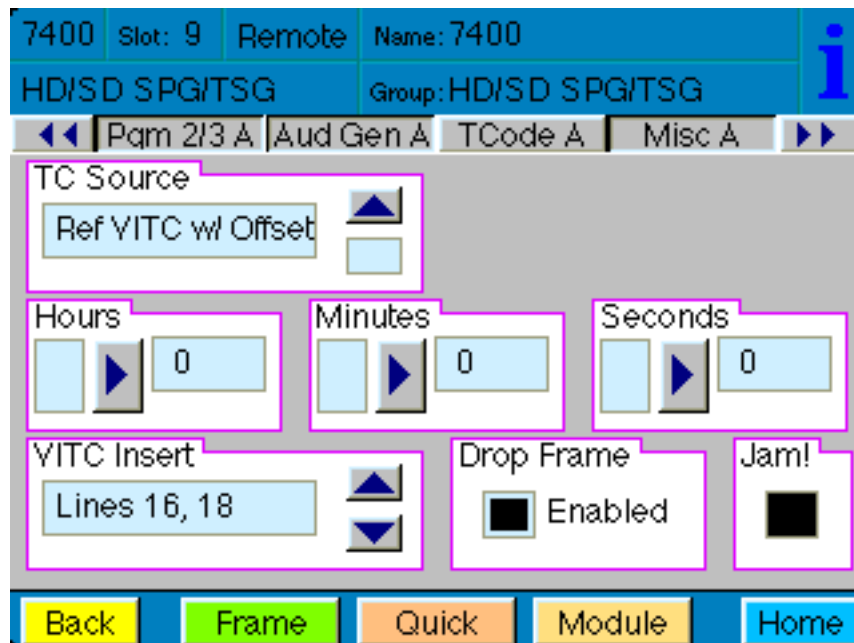

TCode A Touch Screen Menu

Misc A Menu: Setting the Slate, Closed Caption, and Aspect Ratio Parameters

The Misc A menu shown below provides controls for setting parameters for slate text that can overlay the test pattern, a moving cyclops signal with audio pop and beep options, closed caption display options, and AFD code selection for aspect ratio display options.

Use the controls to set the following:

- **Slate ID** – On or Off. Select On if you want to use the Slate feature.
- **Cyclops/Aud ID** – Adds motion, audio pop or beep, and closed caption elements to the video test signal which proves that the signal reaching this destination is a true live signal and not a freeze frame from a frame synchronizer that has lost its input.

Available selections are: Off, Cyclops Only, Cyclops Aud Pop, Cyclops Aud Beep.

- **Slate Text** – Enter the text that you want to overlay on the test pattern and hit enter on your computer keyboard.
- **ANC Source ID** – On or Off. When on, the ANC Source ID control embeds the first 16 characters of the Slate Text into the vertical interval as ancillary data.
- **Closed Cap Gen** – If you are testing closed captions, select one of the closed caption display methods. This impacts how closed captions are displayed on screen.

Available selections are: Off, Hello World, Knock Knock, Pop-On 1, Roll-Up 1, Fast Talk, Special Char, Corners, Italics/UL, Indent, CC1 and CC2.

- **AFD Out** – Active Format Description code selection. This impacts how the aspect ratio of the video content is treated when upconverting or downconverting between the 16:9 and 4:3 aspect ratios. The most commonly used AFD code selections are 1001 and 1010.

Available selections are:

AFD Off
AFD0001
AFD0010
AFD0011
AFD0100
AFD0101
AFD0110
AFD0111
AFD1000
AFD1001
AFD1010
AFD1011
AFD1100
AFD1101
AFD1110
AFD1111

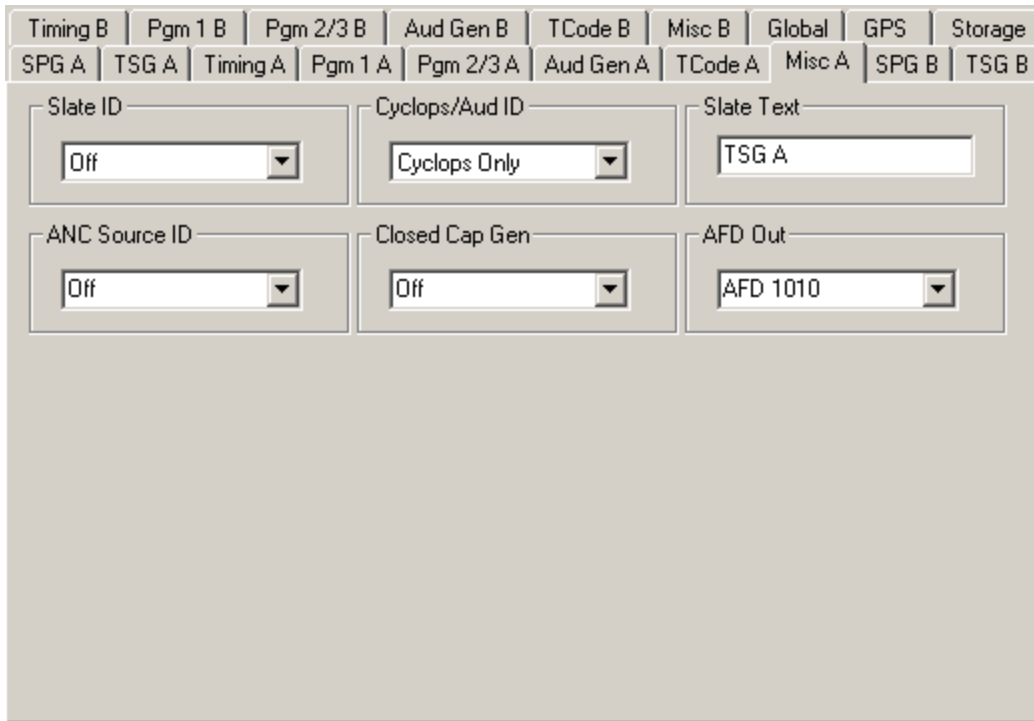

Misc A Avenue PC Menu

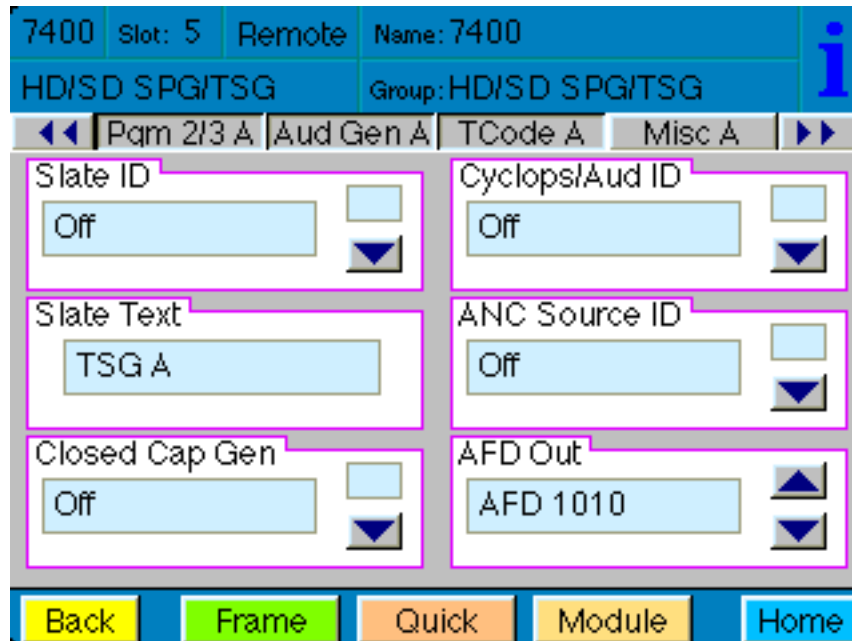

Misc A Touch Screen Menu

Sync Pulse Generator B Menu

Selecting the Reference Source and Output Standard for Sync Pulse Generator B

The **SPG B** menu controls the **SDI Out B** BNC. The standard selected determines what signal will be output on the **SDI Out B** BNC.

Important: Additionally, the standard selected in the **SPG B** menu determines the frame rate family for all of the **Generator B** BNC outputs (**SDI Out B, Out 1 B, Out 2 B, Out 3 B**). For example, if the standard is set to SD 525 or 720p/59.94, then all **Generator B** outputs will be in the 59.94 Hz frame rate family. If the standard is set to SD 625 or 1080i/50, then all **Generator B** outputs will be in the 50 Hz frame rate family.

To select the reference source and output standard of **Sync Pulse Generator B**, select the **SPG B** menu shown below. Set the parameters for the **Source** and **Standard** fields. The standard that the module is locked to is shown in the **Sync Lock** field. Use the controls to set the following:

- **Source** – select the reference source for **Generator B**. Select from:

Internal/GPS – the module’s Internal Precision Standard reference signal, or the signal from the GPS Receiver (with 7400-GPS Option installed). If the GPS signal is present, the 7400 will lock to that. If the GPS signal is not present, the 7400 will lock to its internal TCXO.

Config Ref – locks to the source selected as the **Config Ref** in the **Global** menu. If you choose **Config Ref**, you must have configured that parameter in the **Global** menu. *See the “Global Menu” on page 61 for more information.*

Other Gen – locks to the reference of **Generator A**.

- **Sync Lock** – reports what standard the module is locked to.

Note: If you are using the 7400-GPS option, be sure the H1 jumper on the main module is installed in the GPS position to lock to the GPS reference signal. If the H1 jumper is installed in the INT position it locks to the 7400 or 9400’s internal TCXO (Temperature Compensated Crystal Oscillator). *See the “7400-GPS Option Field Installation Procedure” on page 17 for more information.*

- **Standard** – select the output standard you want from the following:

720p/50	1080p/23.98
720p/59.94	1080p/24
720p/60	1080sF/25
1080i/50	1080sF/23.98
1080i/59.94	1080sF/24
1080i/60	SD 525
1080p/25	SD 625

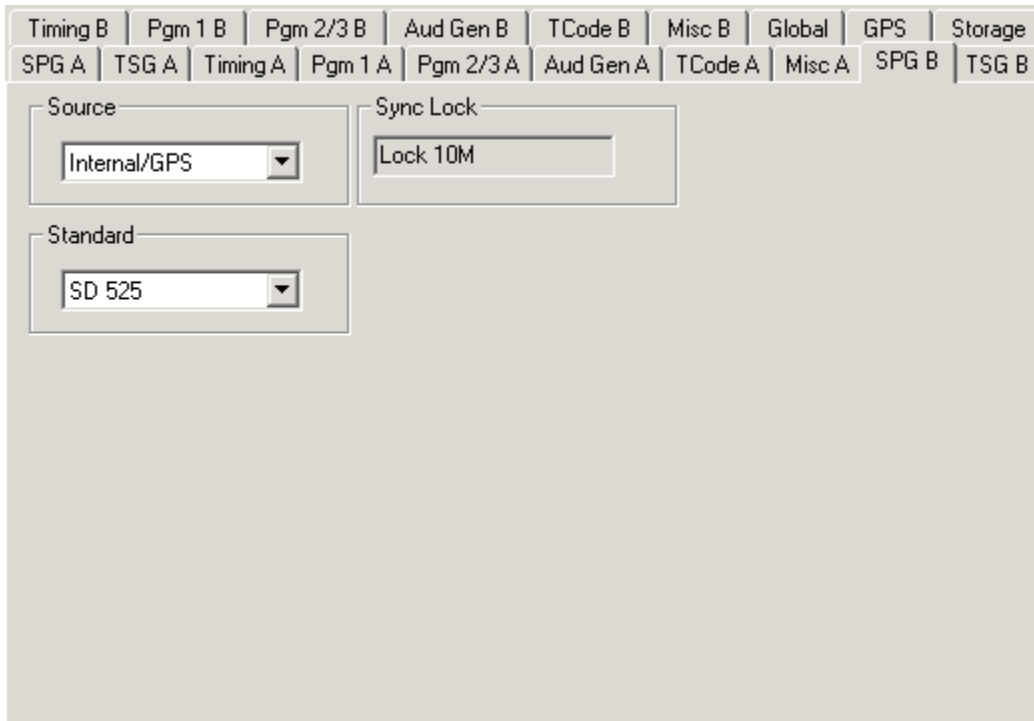

SPG B Avenue PC Menu

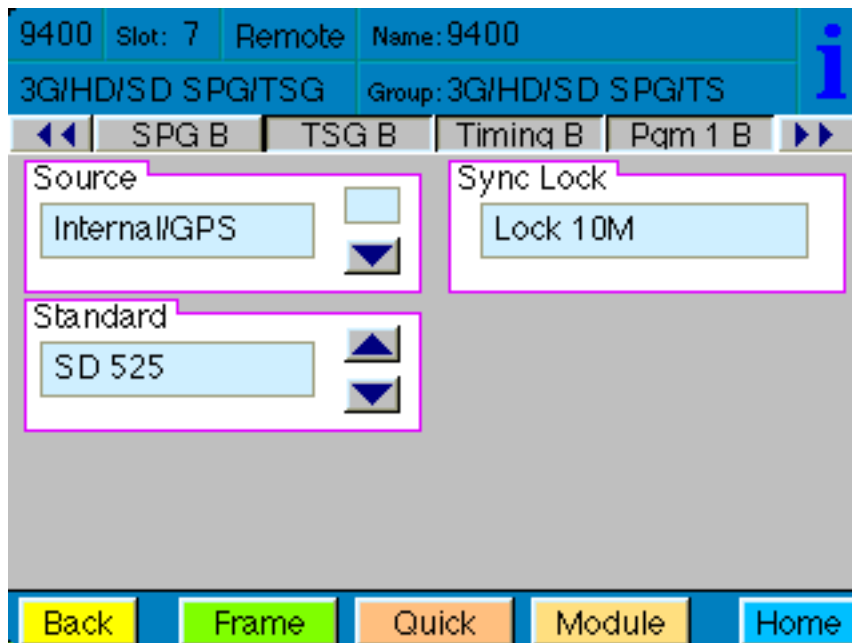

SPG B Touch Screen Menu

Test Signal Generator B Menu

Selecting the Pattern Type, Output Standard and Y, Cr and Cb Channels for Test Signal Generator B

The **TSG B** menu affects the **SDI Out B** BNC. It also affects the **Out 1 B** BNC if it has been set to "Follow SDI."

To set the type of test pattern for the output of **Test Signal Generator B**, select the **TSG B** menu shown below. This menu also has controls for turning on and off the Y, Cr and Cb channels.

Use the controls to set the following:

- **Pattern Type** – Select the pattern group in the first drop-down menu and the test signal in the second drop-down menu.

Pattern Group	Test Signal
Bars	Full Field 75 Full Field 100 SMPTE 75 Split Field 75 Split Field 100 Red Field RGB444 Bars A RGB444 Bars B
Black	Black Flat Field 20 Flat Field 50 Flat Field 80 White RGB444 Black
Ramp	Video Ramp Data Ramp Shallow 5 Step
Sweep	Sweep MultiBurst
Pulse & Bar	Full Field Window Component
Timing	Digital Blanking Cosite Interlace
Misc	Black Crosshatch Safe Title Pathological
Card	Custom Test Patterns from Secure Digital Card

- **Y Channel, Cr Channel, Cb Channel checkboxes** – There are independent enables for each channel so that Y, Cr and Cb can be controlled separately. You may choose to turn off the Y, Cr and/or Cb Channels if desired for test purposes (such as setting up a monitor). To turn off one or more channels, deselect the **Enabled** check box.
- **Number** – The selection available in this menu will reflect the number of custom test patterns loaded onto the SD storage card. A maximum of 255 user-created custom test patterns can be loaded.
- **Name** – Each of the up to 255 custom test patterns will have a name when loaded from the SD storage card. The name of the test pattern selected from the SD card will display in this field.

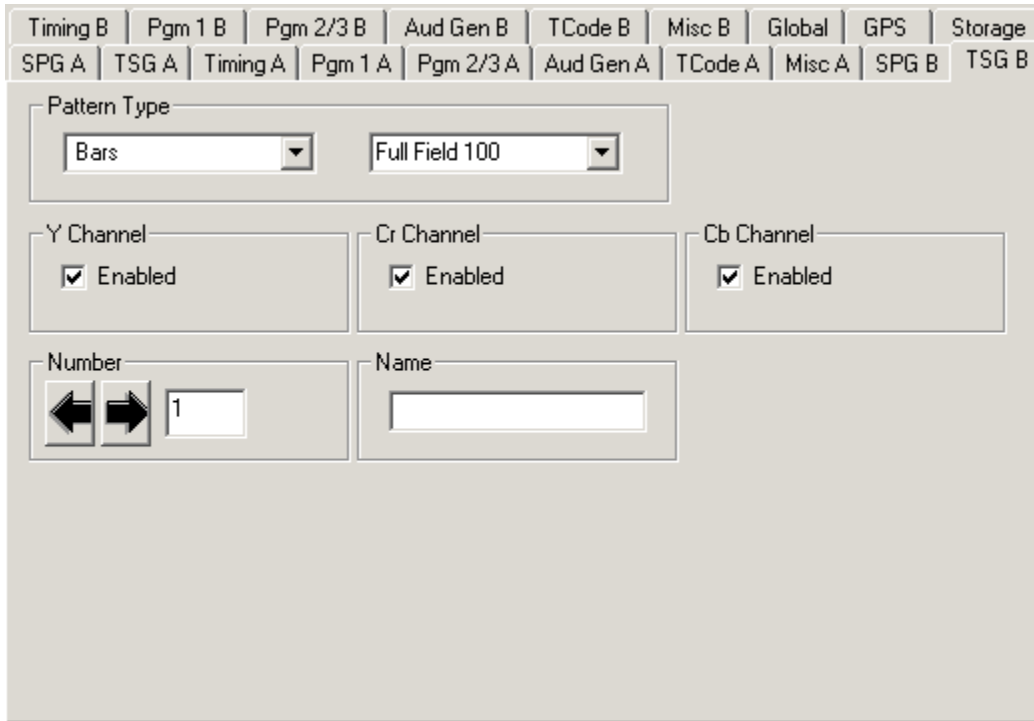

TSG B Avenue PC Menu

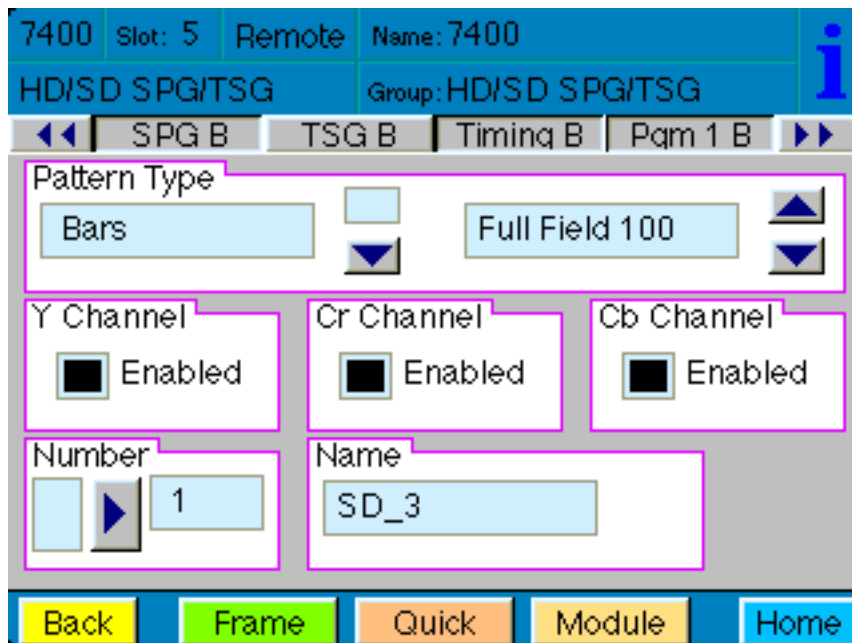

TSG B Touch Screen Menu

Timing B Menu

Setting the Timing for Generator B

The **Timing B** menu shown below allows you to set the timing of the **Generator B** outputs with respect to the reference selected in the **SPG B** menu. This menu affects the SDI output, the principal output of the generator, which applies to **SDI Out B** and **Programmable Output 1 B (Out 1 B BNC)**. Use the slider controls or arrows to select a value or enter a value into the number fields.

- **Vert Timing** – Set the vertical timing in lines. Range is -525 to 525, default is 0.
- **Hor Timing** – Set the horizontal timing in clocks. Range is -1716 to 1716, default is 0.
- **Fine Phase** – Set the fine phase of the Primary output in nanoseconds. Range is -35 to 35, default is 0.

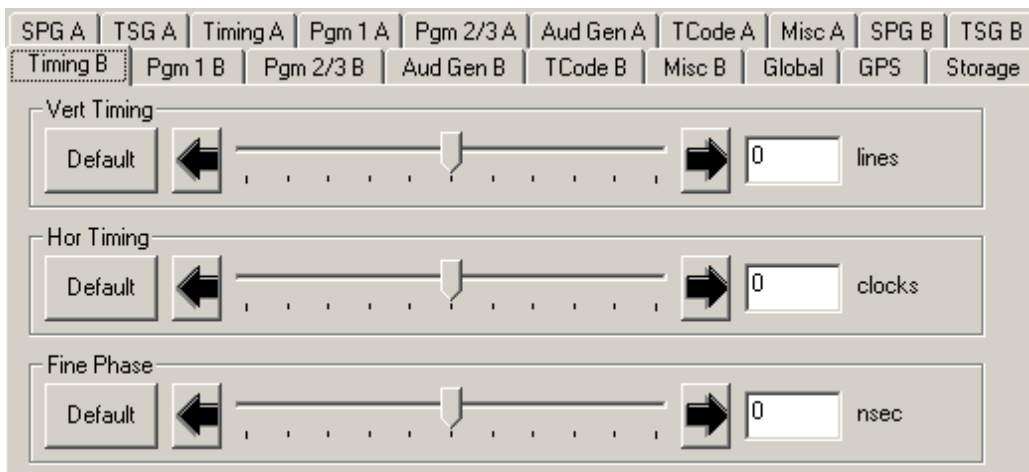

Timing B Avenue PC Menu

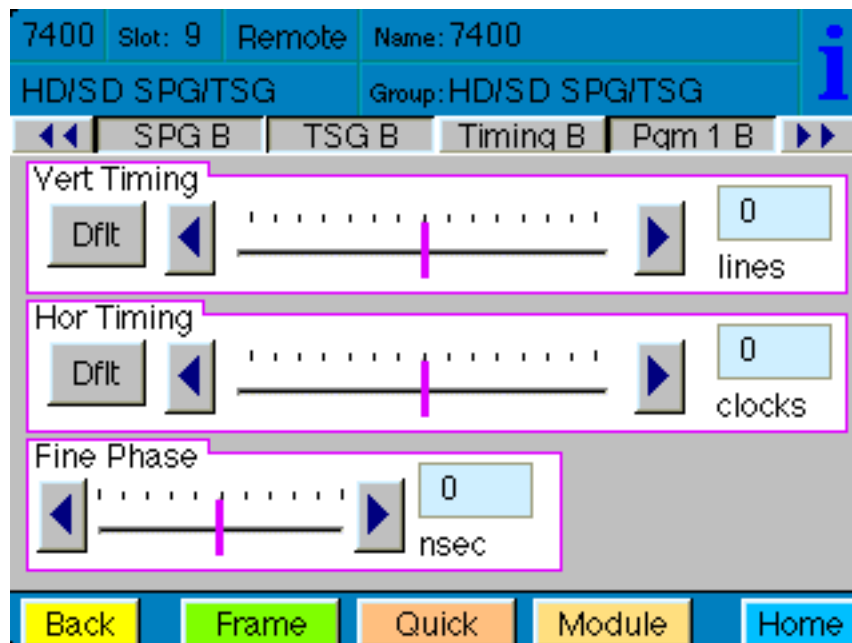

Timing B Touch Screen Menu

Programmable Output 1 B Menu

Setting the Output, Tri-Level Sync Output Standard, Fine Phase , Vertical Timing, and Horizontal Timing for Programmable Output 1 B

The **Pgm 1 B** menu shown below allows you to set the **Programmable Output 1 B**, the Tri-Level Sync output standard, vertical and horizontal timing and fine phase. This menu affects the **Out 1 B** BNC.

Note: The selections you make from the **Pgm 1 OutSel** and **TLS Gen 1 Std** drop-down menus have to be from the same frame rate family as the standard selected in the **SPG B** menu.

Use the controls to set the following:

- **Pgm 1 OutSel** – Choose from:

- Black
- Color Bars
- Follow SDI Out
- TLS Gen 1

When “Follow SDI Out” is selected, the settings from the **TSG B** menu are being used.

- **TLS Gen 1 Std** – Choose an output standard from the following options:

- 720p/50
- 720p/59.94
- 720p/60
- 1080i/50
- 1080i/59.94
- 1080i/60
- 1080p/25
- 1080p/23.98
- 1080p/24
- 1080sF/25
- 1080sF/23.98
- 1080sF/24

Use the slider controls or arrows to select a value or enter a value into the number fields.

- **Fine Phase** – Set the fine phase of the output in nanoseconds. Range is -35 to 35, default is 0.
- **Vert Timing** – Set the vertical timing in lines. Range is -1000 to 1000, default is 0.
- **Hor Timing** – Set the horizontal timing in clocks. Range is -2000 to 2000, default is 0.

Note: If you select “Follow SDI Out” from the **Pgm 1 OutSel** drop-down menu, the **Fine Phase**, **Vert Timing** and **Hor Timing** controls will be grayed out and will not be usable.

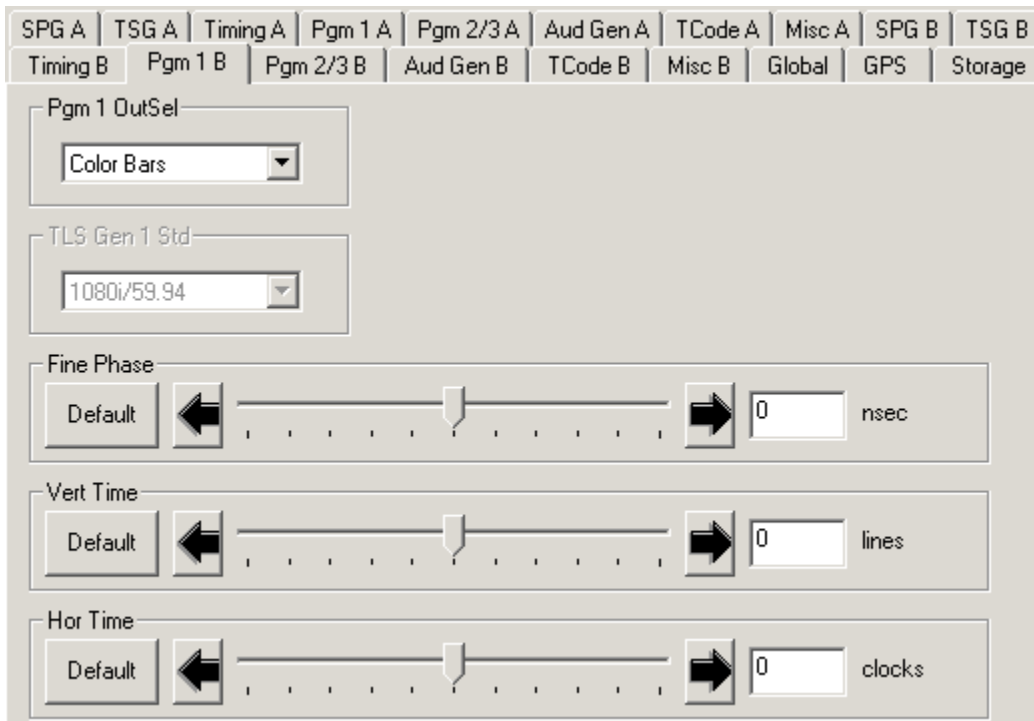

Pgm 1 B Avenue PC Menu

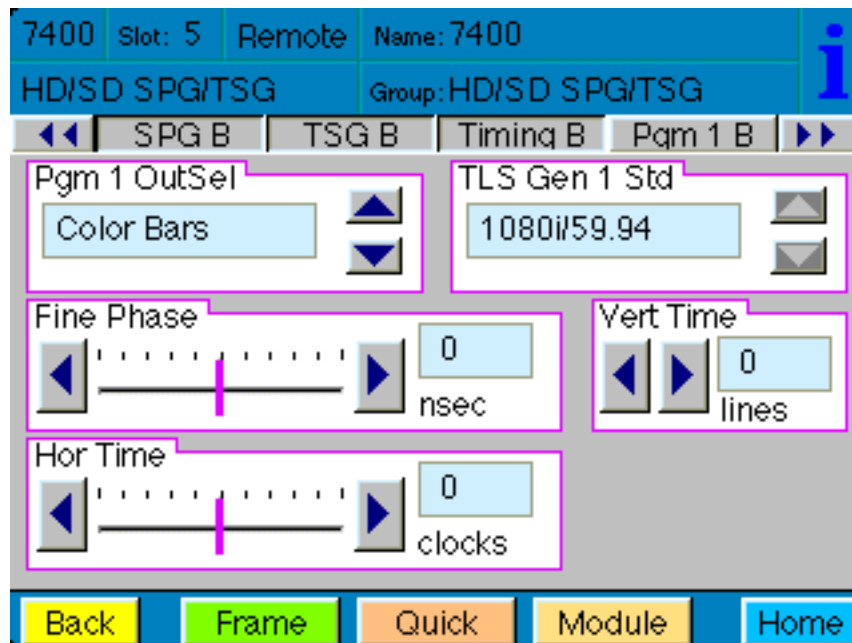

Pgm 1 B Touch Screen Menu

Programmable Output 2 B and 3 B Menu

Setting the Output, Tri-Level Sync Output Standard, Vertical Timing, and Horizontal Timing for Programmable Output 2 B and 3 B

The **Pgm 2/3 B** menu shown below allows you to set the **Programmable Output 2 B and 3 B**, the output standard and the vertical and horizontal timing for Tri-Level Sync Generator 2. This menu affects the **Out 2 B** and **Out 3 B** BNCs.

Use the controls to set the following:

- **Pgm 2 OutSel** – Affects **Out 2 B** BNC. Choose from:

- TLS Gen 2
- LTC Timecode
- AES Audio 1/2
- AES Audio 3/4
- AES Audio 5/6
- AES Audio 7/8
- AES Audio 9/10
- AES Audio 11/12
- AES Audio 13/14
- AES Audio 15/16
- AES Silence
- Word Clock
- 6Hz Pulse
- 10MHz Clock

- **Pgm 3 OutSel** – Affects **Out 3 B** BNC. Choose from:

- TLS Gen 2
- LTC Timecode
- AES Audio 1/2
- AES Audio 3/4
- AES Audio 5/6
- AES Audio 7/8
- AES Audio 9/10
- AES Audio 11/12
- AES Audio 13/14
- AES Audio 15/16
- AES Silence
- Word Clock
- 6Hz Pulse
- 10MHz Clock

- **TLS Gen 2 Std** – Choose the output standard for Tri-Level Sync Generator 2. Choose from:

720p/50
720p/59.94
720p/60
1080i/50
1080i/59.94
1080i/60
1080p/25
1080p/23.98
1080p/24
1080sF/25
1080sF/23.98
1080sF/24

- **TLS 2 V Time** – Set the vertical timing in lines for **Tri-Level Sync Generator 2**. Range is -1000 to 1000, default is 0. Use the slider controls or arrows to select a value or enter a value into the number field.
- **TLS 2 H Time** – Set the horizontal timing in clocks for **Tri-Level Sync Generator 2**. Range is -2000 to 2000, default is 0. Use the slider controls or arrows to select a value or enter a value into the number field.

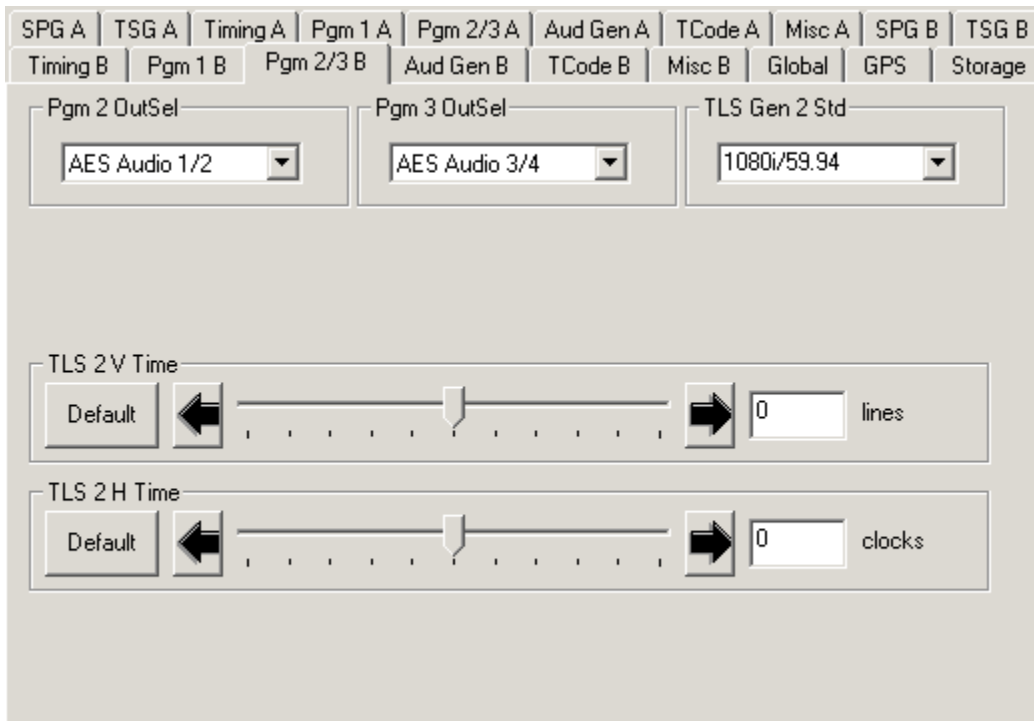

Pgm 2/3 B Avenue PC Menu

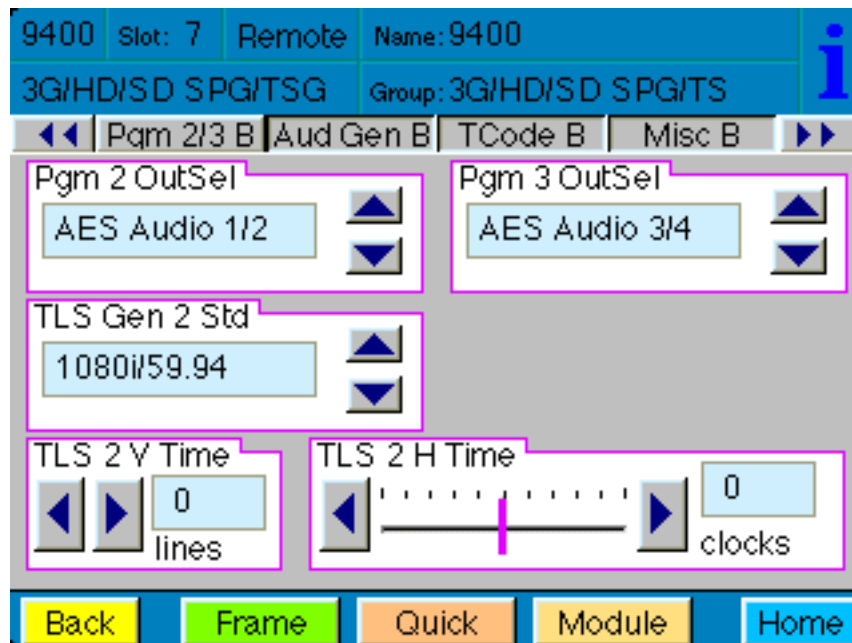

Pgm 2/3 B Touch Screen Menu

Audio Generator B Menu

Setting the Audio Generation and Routing Parameters for Audio Generator B

There are two generators on each 7400 or 9400, **Generator A** and **Generator B**. Each of the two generators are identical, with completely independent controls. The two AES digital audio outputs are always synchronous with all of the video outputs – regardless of format – because all of the video outputs can be locked to a common time base. Multiple tone generators can be used to identify multi-channel content. Each generator supports sixteen audio channels and the content of each channel is independently programmable. Choices include adjustable frequency tone generators, tone sweeps, silence, timecode, audio clip playback from the 7400's secure digital card, and the external AES input. All sixteen of these channels can be embedded in the SDI outputs. Each AES output can select from any of the eight pairs that make up these sixteen channels.

This menu affects the **Out 2 B** and **Out 3 B** BNCs.

There are three types of audio output:

Embedded – audio embedded on the SDI output

AES – goes to user-programmable output 2 (**Out 2 B**) and 3 (**Out 3 B**)

Analog – output goes to **15-pin D connector**

The **Aud Gen B** menu shown below allows you to set the **Channel Number**, the **Audio Source**, to make Embedded Audio selections, and to choose the channel for **Analog Out**.

Use the controls to set the following:

- **Chan Number** – Available selections are 1 through 16
- **Audio Source** – Available selections are:
 - 300Hz Tone
 - 400Hz Tone
 - 500Hz Tone
 - 600Hz Tone
 - 800Hz Tone
 - 1.0KHz Tone
 - 1.2KHz Tone
 - 1.6KHz Tone
 - Silence
 - TSG Audio
 - Timecode
- **Embed Grp 1 through 4**
 - Group 1 includes channels 1/2 and 3/4
 - Group 2 includes channels 5/6 and 7/8
 - Group 3 includes channels 9/10 and 11/12
 - Group 4 includes channels 13/14 and 15/16

- **Analog Out** – Available selections are:

Channels 1/2
 Channels 3/4
 Channels 5/6
 Channels 7/8
 Channels 9/10
 Channels 11/12
 Channels 13/14
 Channels 15/16

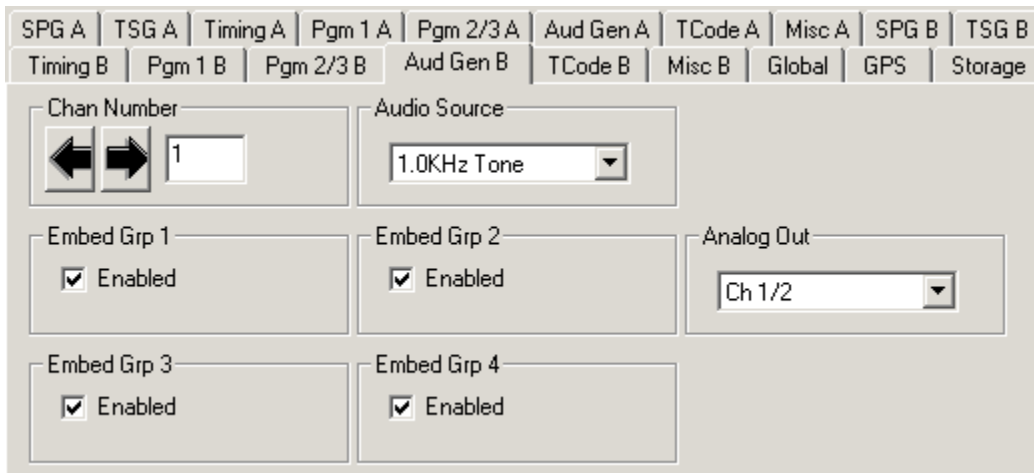

Aud Gen B Avenue PC Menu

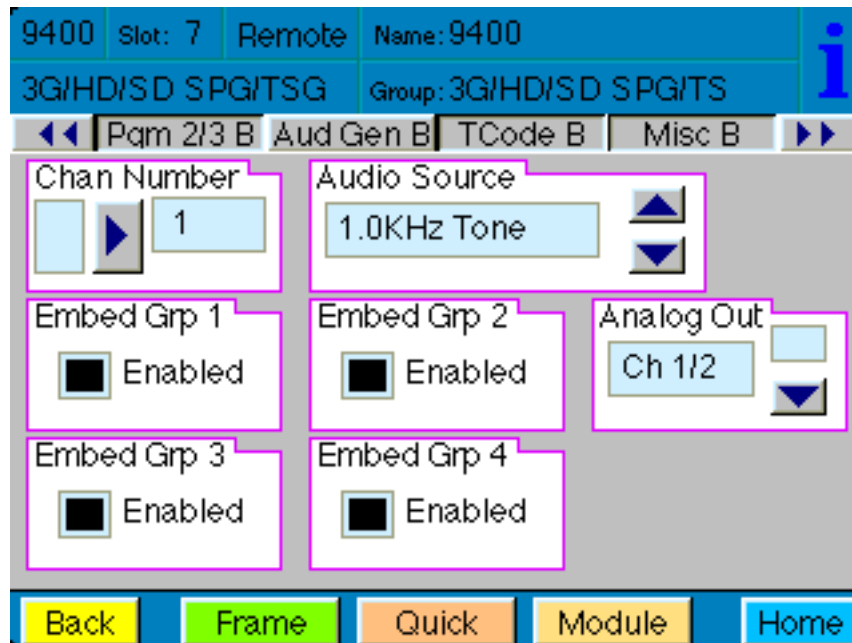

Aud Gen B Touch Screen Menu

Timecode B Menu

Setting the Timecode Parameters for Timecode B

The **TCODE B** menu shown below provides controls to select your timecode source, manually set or offset timecode, insert VITC, and enable drop frame for Timecode Generator B.

Use the controls to set the following:

TC Source – Available choices for timecode source are:

Manual/Jam – For entering a timecode manually.

GPS – For basing the timecode on the GPS source.

Ref VITC – For basing the timecode on the Reference vertical interval timecode.

Ref VITC w/ Offset – For basing the timecode on the Reference VITC, but offset by the amount of time entered manually in the Hours/Minutes/Seconds controls.

Manual – Manually set or offset the timecode. These controls are used to manually enter the time in the **Manual/Jam** mode, and to manually offset the timecode when the timecode source is **Ref VITC with Offset**. These controls will be greyed out and will not be usable when the timecode source is **GPS**.

Hours – 0 through 23

Minutes – 0 through 59

Seconds – 0 through 59

- **VITC Insert** – Select from Off or one of the following a pair of lines: 13, 15; 14, 16; 15, 17; 16, 18; 17, 19; 18, 20; 19, 21.
- **Drop Frame** – Select the checkbox to enable Drop Frame (dropping two frames every minute except on every tenth minute) to allow timecode to match a real-time clock.
- **Jam!** – To manually enter the starting timecode value, enter the desired values in the **Hours**, **Minutes** and **Seconds** fields, then click the **Jam!** button.

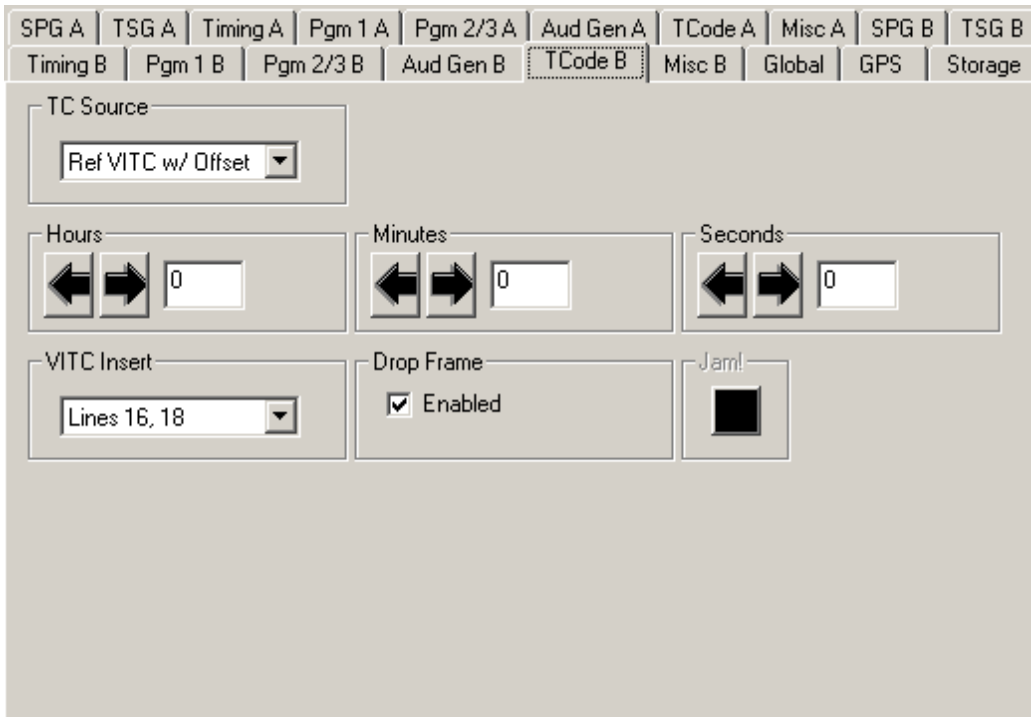

TCode B Avenue PC Menu

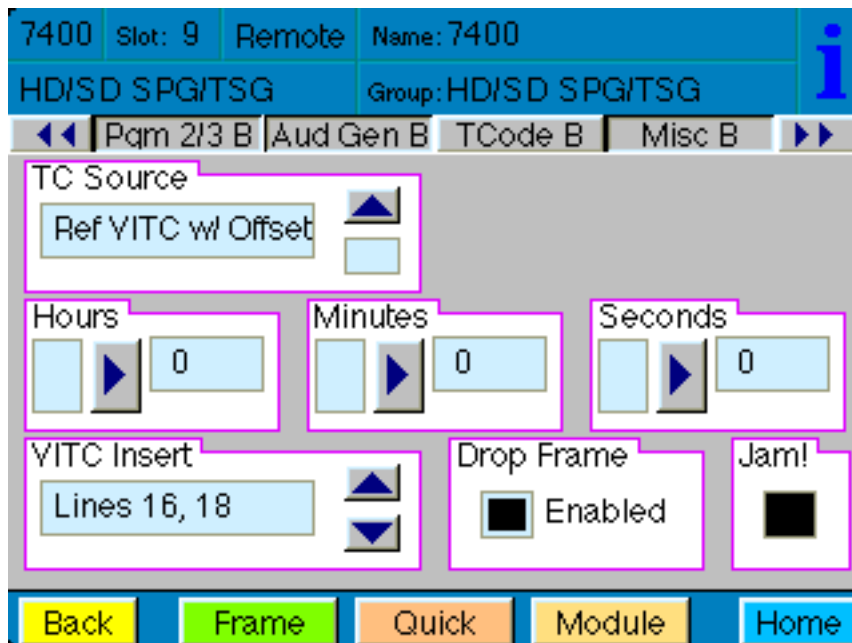

TCode B Touch Screen Menu

Misc B Menu: Setting the Slate, Closed Caption, and Aspect Ratio Parameters

The **Misc B** menu shown below provides controls for setting parameters for slate text that can overlay the test pattern, a moving cyclops signal with audio pop and beep options, closed caption display options, and AFD code selection for aspect ratio display options.

Use the controls to set the following:

- **Slate ID** – On or Off. Select On if you want to use the Slate feature.
- **Cyclops/Aud ID** – Adds motion, audio pop or beep, and closed caption elements to the video test signal which proves that the signal reaching this destination is a true live signal and not a freeze frame from a frame synchronizer that has lost its input.

Available selections are: Off, Cyclops Only, Cyclops Aud Pop, Cyclops Aud Beep.

- **Slate Text** – Enter the text that you want to overlay on the test pattern and hit enter on your computer keyboard.
- **ANC Source ID** – On or Off. When on, the ANC Source ID control embeds the first 16 characters of the Slate Text into the vertical interval as ancillary data.
- **Closed Cap Gen** – If you are testing closed captions, select one of the closed caption display methods. This impacts how closed captions are displayed on screen.

Available selections are: Off, Hello World, Knock Knock, Pop-On 1, Roll-Up 1, Fast Talk, Special Char, Corners, Italics/UL, Indent, CC1 and CC2.

- **AFD Out** – Active Format Description code selection. This impacts how the aspect ratio of the video content is treated when upconverting or downconverting between the 16:9 and 4:3 aspect ratios. The most commonly used AFD code selections are 1001 and 1010.

Available selections are:

AFD Off
AFD0001
AFD0010
AFD0011
AFD0100
AFD0101
AFD0110
AFD0111
AFD1000
AFD1001
AFD1010
AFD1011
AFD1100
AFD1101
AFD1110
AFD1111

SPG A	TSG A	Timing A	Pgm 1 A	Pgm 2/3 A	Aud Gen A	TCode A	Misc A	SPG B	TSG B
Timing B	Pgm 1 B	Pgm 2/3 B	Aud Gen B	TCode B	Misc B	Global	GPS	Storage	

Slate ID Off	Cyclops/Aud ID Cyclops Aud Beep	Slate Text TSG B
ANC Source ID Off	Closed Cap Gen Off	AFD Out AFD Off

Misc B Avenue PC Menu

9400	slot: 7	Remote	Name: 9400	i
3G/HD/SD SPG/TSG			Group: 3G/HD/SD SPG/TS	
Pgm 2/3 B		Aud Gen B	TCode B	Misc B
Slate ID Off	Cyclops/Aud ID Off	Slate Text TSG B	ANC Source ID Off	
Closed Cap Gen Off	AFD Out AFD Off			
Back	Frame	Quick	Module	Home

Misc B Touch Screen Menu

Global Menu

Setting Global Parameters for Module Reference and Audio Reference Levels

The parameters set in the **Global** menu affect the entire 7400 or 9400 module. These settings can be applied to **Generator A** and **Generator B**.

The **Global** menu shown below allows you to set the parameters for Configuration Reference, Vertical Interval Time Code, Digital Audio Reference Level, Analog Audio Tone Output and Composite Setup.

Use the controls to set the following:

- **Config Ref** – Select the desired module reference from the **External Reference** (525, 625, Tri-Level Sync or 10 MHz sine wave) or **Master Reference** (Frame Reference). The presence of the reference will be reported in the adjacent **Reference** window.
- **Ref VITC Line** – Specify the line on which you want to put the Vertical Interval Time Code.

Available selections are: Line 12, Line 13, Line 14, Line 15, Line 16, Line 17, Line 18, Line 19.
- **Reference** – Reports what reference input is present from the following list:

No Ref, Ref 525, Ref 525 w/VITC, Ref 625, Ref 625 w/VITC, Ref TLS 720p60 (reports this for 59.94 and 60), Ref TLS 720p50, Ref TLS 1080i60 (reports this for 59.94 and 60), Ref TLS 1080i50 (also reports this for 1080p 25 and 1080sF 25), Ref TLS 1080i24 (reports this for 1080p 23.98 or 24 and 1080sF 23.98 or 24), Ref 10MHz.
- **Dig Ref Level** – Digital Audio Reference Level. Applies to AES digital. -20dBFS or -18dBFS.
- **Anlg Ref Level** – Set the Analog Reference Level.

Available selections are: -10dB, -6dB, -4dB, 0dB, +4dB.
- **Cpst Setup** – Turns Composite Setup On or Off for 525/60 Hz outputs. For most 60 Hz applications, this option is typically enabled.

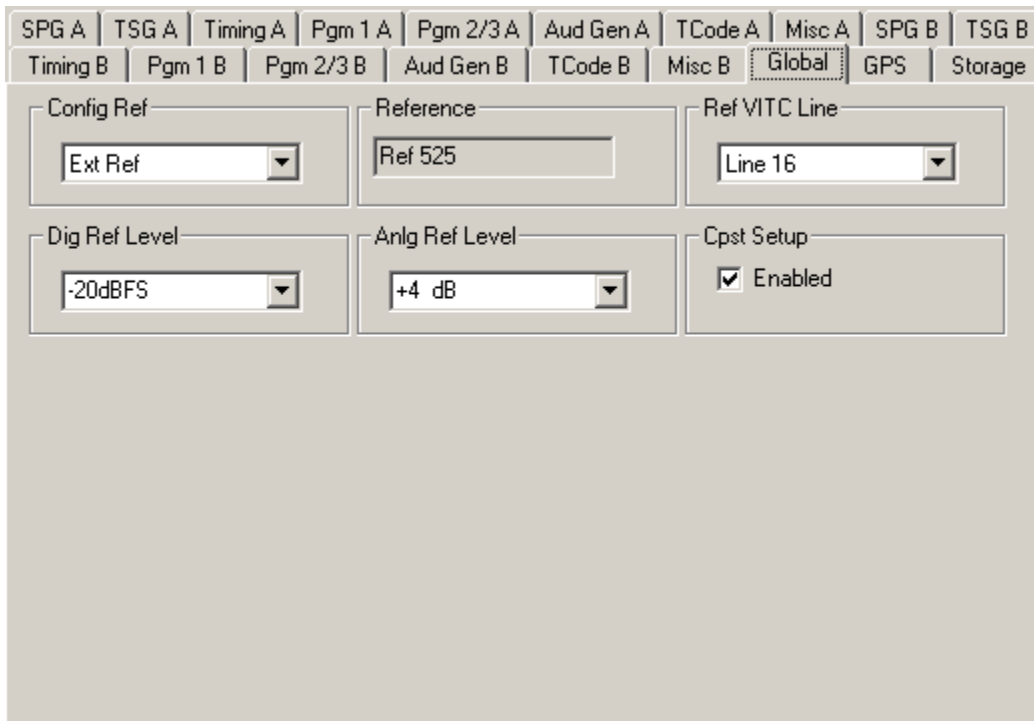

Global Avenue PC Menu

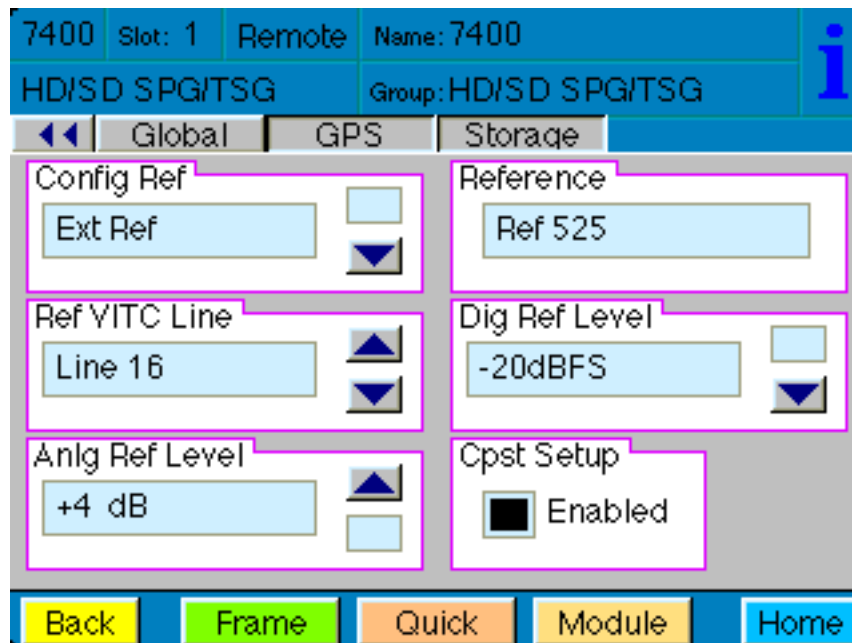

Global Touch Screen Menu

GPS Menu

The **GPS** menu shown below allows you to monitor the GPS status and set the parameters for UTC Offset and Automatic Daylight Saving Time controls for Models 7400 and 9400 that have the optional 7400-GPS Option installed.

- **GPS Status** – Possible values are: Normal Operation; No Satellites; Antenna Open; Antenna Shorted, Not Installed.

Normal Operation – the GPS function is operating normally.

No Satellites – This may indicate that the Avenue module is still in the process of establishing a connection to the satellites. When first setting up the GPS functionality, it is normal for the process to take up to one hour to establish proper satellite connections.

Antenna Open – This status means that there is a loose cable connection, either between the 7400 module and the GPS sub-module, or between the 7400 or 9400 and the antenna. Make sure that you have installed the GPS submodule properly and installed the H1 jumper in the GPS position. Check the GPS sub-module connections as well as the connections to the antenna to make sure that everything is connected properly. *See the “7400-GPS Option Field Installation Procedure” on page 17 for more information.*

Antenna Shorted – This indicates that there is a short somewhere between the Avenue Frame and the antenna.

Not Installed – The GPS sub-module is not installed on the Avenue 7400 or 9400 module.

- **UTC Offset** – The UTC Offset is used to configure Models 7400 and 9400 so that the time that is loaded into the timecode generator from the GPS is properly offset to the local time zone. The UTC in the 7400 or 9400 module follows the North American practice.

The UTC Offset available menu options are -12 to 12, offset in hours. As an example, the setting for the Pacific Time Zone in North America (Los Angeles) is an offset of -8

Note: UTC stands for Coordinated Universal Time, formerly known as GMT (Greenwich Mean Time)

- **Auto DST** – Turn this feature **On** or **Off**.

When the Auto DST function in **On**, timecode will automatically be adjusted forward by an hour in the spring and back by an hour in the fall. If you want this auto functionality, leave the Auto DST function **On** all year round.

If you want to adjust for Daylight Saving Time manually, turn the Auto DST function **Off** and change the UTC by one hour manually on the designated dates in the spring and fall.

Note that the calendar rules used for the beginning and ending of Daylight Saving Time by the 7400 GPS Option are based upon the practice in North America.

- **Date in TC** – On or Off. This control allows insertion of the date in all of the Timecode Outputs of the Module

On – The date is inserted in all of the Timecode Outputs of the module, listed below. The date is inserted in accordance with SMPTE Standard 309 in MJD (Modified Julian Date).

Timecode Outputs on Models 7400 and 9400:

LTC – “audio” style output

VITC – vertical interval in Analog SD

DVITC – vertical interval in SD SDI

ATC – vertical interval in HD SDI

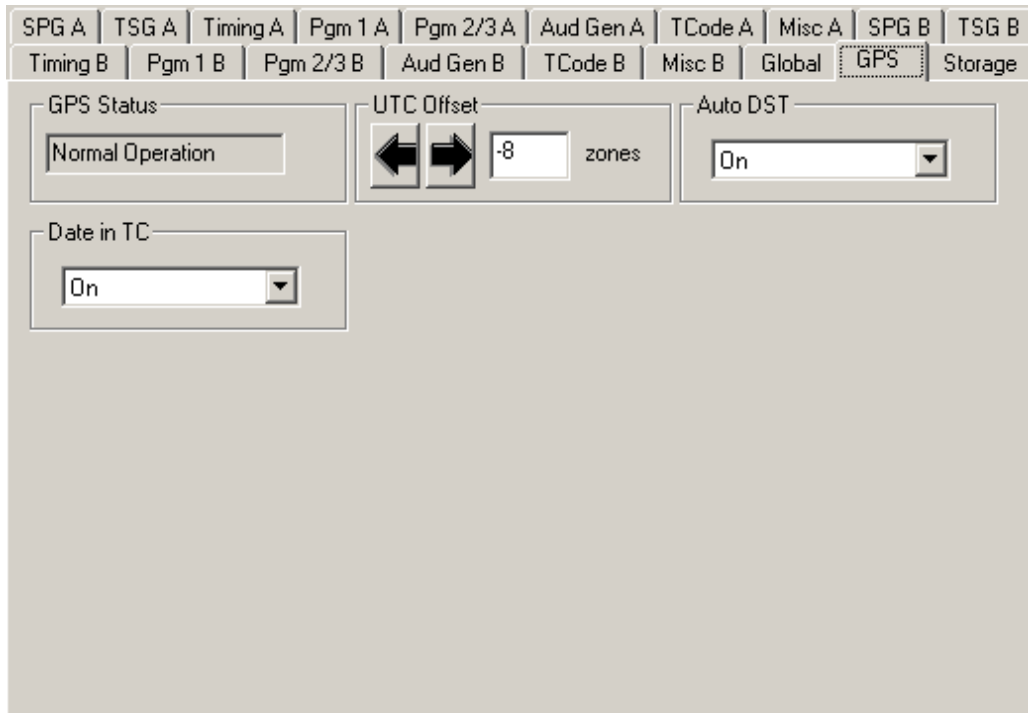

GPS Avenue PC Menu

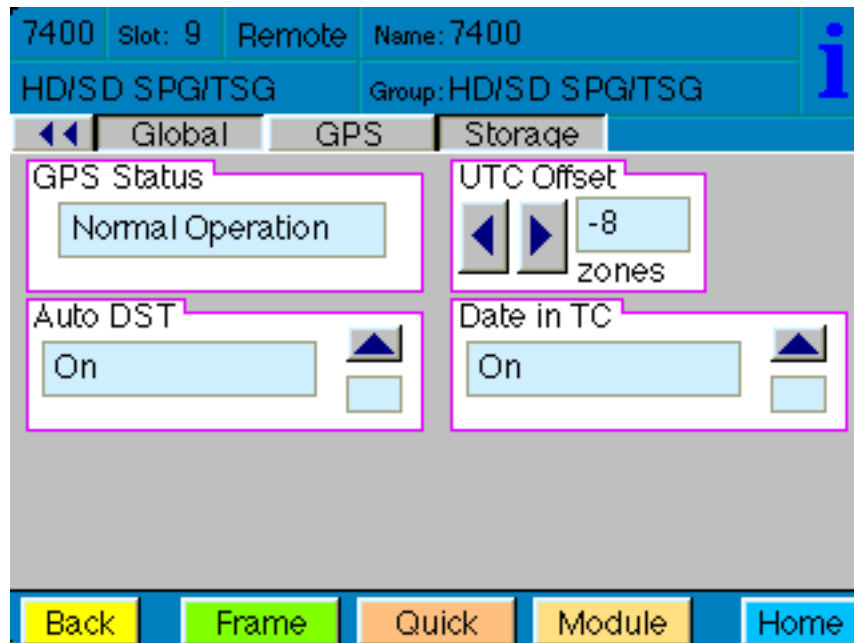

GPS Touch Screen Menu

Storage Menu

Loading Custom Test Signals, Viewing SD Card and RAM Status

With the **Storage** menu shown below, you can view the SD card status, load custom test signals from the SD card, and view the amount of RAM available for both generators. Each 7400 and 9400 comes with a 2 GB SD Flash Memory card for storing your custom test patterns. Additionally, each 7400 and 9400 ships with two 512 MB DDR2 RAM cards installed on the back of the module, these can be field upgraded to up to 2 GB each if desired.

Use the **Load** button to load your custom test signals from the SD Card.

The **Storage** menu also provides these reporting fields:

- **SD Card Status** – Reflects the status of the SD Card; None, Error, Busy or Ready.
- **RAM Module 1** – Shows the RAM capacity of Generator 1; None, Bad Memory, 256 MB, 512 MB, 1 GB, 2 GB.
- **RAM Module 2** – Shows the RAM capacity of Generator 2; None, Bad Memory, 256 MB, 512 MB, 1 GB, 2 GB.

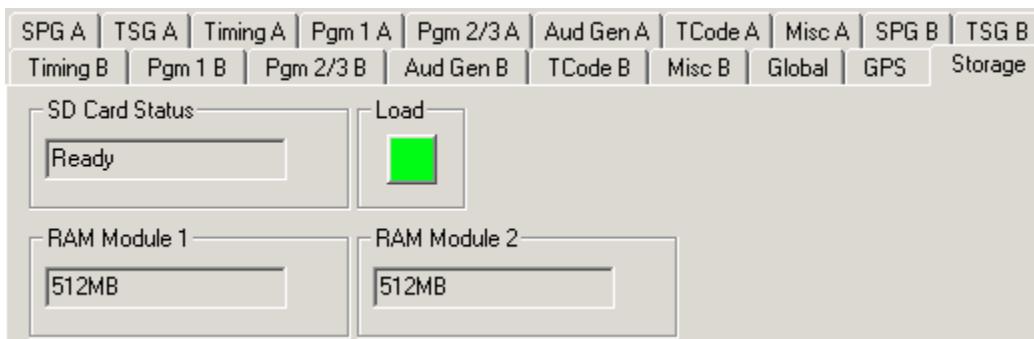

Storage Avenue PC Menu

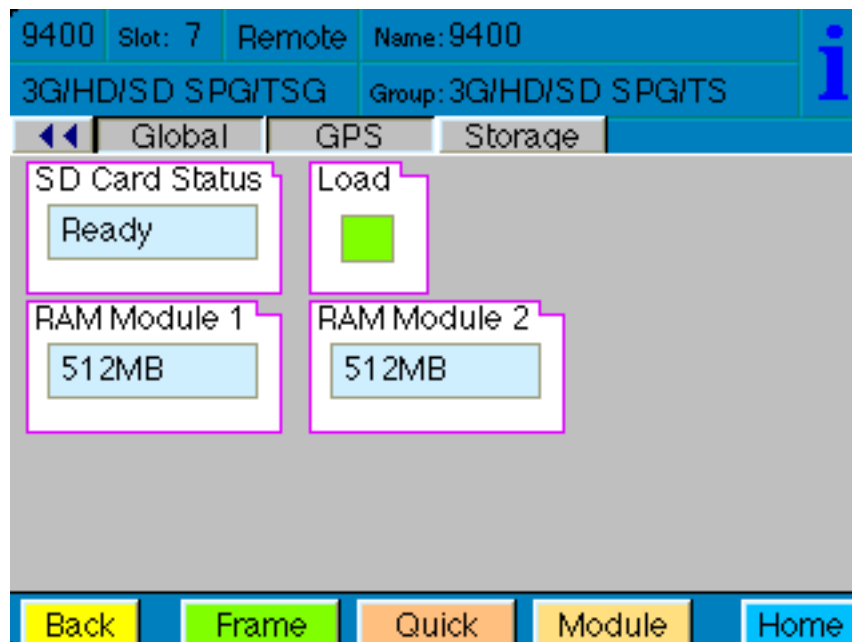

Storage Touch Screen Menu

Troubleshooting

As a troubleshooting aid, the reference signal status and presence, power and CPU status can be easily monitored from the front panel of this module using the front panel indicators.

Refer to the overall troubleshooting tips given below for Models 7400 and 9400:

No Generator A or Generator B LED indication

- Generator is not locked to its timing source. At least one of the Generator A or Generator B LEDs should be lit to indicate the primary output line standard and that it is locked to its timing source. Check source settings in the Global, SPG A and SPG B menus.

Cannot control module

- Check status of CPU Run green LED. Should be blinking slowly and in unison with other modules if System Control module is present. If not, try removing the 7400 or 9400 module and plugging it in again to be sure it is seated properly.
- System module may not be working properly if installed.

Module controls are grayed out

- Module is locked or access to module controls is restricted by the User Level which is set in Avenue PC.

No signal out of module

- Check status of Ref green LEDs. One should be lit to indicate which reference rate is currently being detected. If not, check the reference input or master frame signal for presence and quality.
- Check cabling to input of module.

You may also refer to the technical support section of the Ensemble Designs web site for the latest information on your equipment at the URL below:

<http://www.ensembledesigns.com/support>

Software Updating

Software upgrades for each module can be downloaded remotely if the optional System Control module is installed. Software updates are easy to access and free on our web site:

www.ensembledesigns.com/support/avenue-support/

Use Avenue Mac or PC software to install the software update into your Avenue module. If you do not have the required System Control Module and Avenue PC, modules can be sent back to the factory for software upgrades.

Warranty and Factory Service

Warranty

Ensemble Designs, Inc. warrants this product to be free from defect in material and workmanship for a period of 5 years from the date of delivery. During this 5 year warranty period, Ensemble Designs, Inc. will repair any defective modules at Ensemble's expense if the module should be determined to be defective after consultation with a factory technician.

This warranty is not transferable. Any implied warranties expire at the expiration date of this warranty.

This warranty does not cover a defect that has resulted from improper or unreasonable use or maintenance as determined by us. This warranty is void if there is any attempt to disassemble or adjust factory set presets without factory authorization.

Factory Service

If you require service (under warranty or not), please contact Ensemble Designs and ask for Customer Service before you return the unit. This will allow the service technician to provide any other suggestions for identifying the problem and recommend possible solutions.

You may also refer to the technical support section of the Ensemble web site for the latest information on your equipment at the URL below:

<http://www.ensembledesigns.com/support>

If you return equipment for repair, please get a Return Material Authorization Number (RMA) from the factory first.

Ship the product and a written description of the problem to:

Ensemble Designs, Inc.
Attention: Customer Service
RMA #####
870 Gold Flat Rd.
Nevada City, CA 95959 USA

tel: +1 530.478.1830
Fax: +1 530.478.1832
email: service@ensembledesigns.com

Be sure to put your RMA number on the outside of the box.

Specifications for Models 7400 and 9400

Standards Supported

1080i 50, 59.94 or 60 Hz, SMPTE 274M -4,5,6
720p 50, 59.94 or 60 Hz, SMPTE 296M -1,2,3
1080p 23.98, 24 or 25 Hz, SMPTE 274M -9,10,11
1080sF 23.98, 24 or 25 Hz, RP211 -14,15,16
3 Gb/s Level A or Level B, SMPTE 424M, 425M **9400 only**
625i 50
525i 59.94
Composite PAL, NTSC

Frame Rate Families

Each 7400 and 9400 has 2 identical Generators, each with a variety of outputs. All of the outputs from a particular Generator must be selected within the same frame rate family.

50 Hz (625) Derived Family: 1080i/50, 720p/50, 1080p/25, 1080sF/25, 625i/50
59.94 Hz (525) Derived Family: 1080i/59.94, 720p/59.94, 1080p/23.98, 1080sF/23.98, 525i/59.94
60 Hz Derived Family: 1080i/60, 720p/60, 1080p/24, 1080sF/24

Reference Input

Number	Two: External or Frame Master Reference
Signal Type	PAL or NTSC composite video or HD Tri-Level Sync or 10 MHz 1V P-P sine or square
Return Loss	>40 dB (applies to external ref input)

Serial Digital Outputs

Type	HD Serial Digital 1.485 Gb/s, SMPTE 274M, 292M, 296M HD Serial Digital 2.97 Gb/s, SMPTE 424M, 425M 9400 only or SD Serial Digital 270 Mb/s, SMPTE 259M
Impedance	75 Ω
Return Loss	>15 dB
Max Cable Length	300 meters for SD 270 Mb/s (Belden 1694A) 100 meters for HD 1.485 Gb/s (Belden 1694A) 70 meters for HD 2.97 Gb/s HD (Belden 1694A) 9400 only

Tri-Level Sync Outputs

Signal Type	HD Tri-Level Sync
Output DC	± 50 mV
Return Loss	>30 dB to 30 MHz

Composite Outputs

Signal Type	NTSC / PAL
Impedance	75 Ω
Return Loss	>40 dB DC to 5.5 MHz
Frequency Response	± 0.1 dB 0 to 5.0 MHz
Output DC	± 50 mV
K Factor	<1.0%
Differential Phase	<1.0 degree
SCH Phase	± 2 degrees
Delay	adjustable over full frame in sub degree steps
Color Framing	tracks ref

Accuracy

Internal Reference (TCXO)

Freq Error	<10 ⁻⁷ < ± 1 Hz F _{sc}
------------	---

GPS Option

Freq Error	<10 ⁻¹²
------------	--------------------

Stability

Analog Jitter	<1 ns
Digital Jitter	<0.2 UI (0.13 UI typical)
AES Jitter	<1 ns

AES Audio Outputs

Type	AES3id tone, 300 Hz to 1.6 KHz, or silent
Resolution	24 bit

Analog Audio Outputs

Number	Two stereo pairs or four mono
Type	tone, 300 Hz to 1.6 KHz, or silent
Impedance	30 Ω , balanced
Reference Level	-10 to + 4 dBu, selectable

Additional Output Choices

Timecode	DVITC on the SDI outputs VITC on the composite outputs LTC on BNC unbalanced or on HD-15 balanced, 1 V P-P drop or non-drop for NTSC date and time insertion when 7400-GPS Option is installed
6 Hz Pulse	
Word Clock	
10 MHz	when locked to internal or GPS reference

Flash Memory

Number	One
Type	Secure Digital SD Flash Memory Card
Size	2 GB card included
Video File Type	.tga

General Specifications

Power Consumption	10 watts
Temperature Range	0 to 40°C ambient (all specs met)
Relative Humidity	0 to 95%, noncondensing
Altitude	0 to 10,000 ft

Glossary

AES/EBU

The digital audio standard defined as a joint effort of the Audio Engineering Society and the European Broadcast Union. AES/EBU or AES3 describes a serial bitstream that carries two audio channels, thus an AES stream is a stereo pair. The AES/EBU standard covers a wide range of sample rates and quantizations (bit depths). In television systems, these will generally be 48 KHz and either 20 or 24 bits.

AFD

Active Format Description is a method to carry information regarding the aspect ratio of the video content. The specification of AFD was standardized by SMPTE in 2007 and is now beginning to appear in the marketplace. AFD can be included in both SD and HD SDI transport systems. There is no legacy analog implementation. (See WSS).

ASI

A commonly used transport method for MPEG video streams, ASI or Asynchronous Serial Interface, operates at the same 270 Mb/s data rate as SD SDI. This makes it easy to carry an ASI stream through existing digital television infrastructure. Known more formally as DVB-ASI, this transport mechanism can be used to carry multiple program channels.

Aspect Ratio

The ratio of the vertical and horizontal measurements of an image. 4:3 is the aspect ratio for standard definition video formats and television and 16:9 for high definition. Converting formats of unequal ratios is done by letterboxing (horizontal bars) or pillar boxing (vertical pillars) in order to keep the original format's aspect ratio.

Bandwidth

Strictly speaking, this refers to the range of frequencies (i.e. the width of the band of frequency) used by a signal, or carried by a transmission channel. Generally, wider bandwidth will carry and reproduce a signal with greater fidelity and accuracy.

Beta

Sony Beta SP video tape machines use an analog component format that is similar to SMPTE, but differs in the amplitude of the color difference signals. It may also carry setup on the luminance channel.

Bit

A binary digit, or bit, is the smallest amount of information that can be stored or transmitted digitally by electrical, optical, magnetic, or other means. A single bit can take on one of two states: On/Off, Low/High, Asserted/ Deasserted, etc. It is represented numerically by the numerals 1 (one) and 0 (zero). A byte, containing 8 bits, can represent 256 different states. The binary number 11010111, for example, has the value of 215 in our base 10 numbering system. When a value is carried digitally, each

additional bit of resolution will double the number of different states that can be represented. Systems that operate with a greater number of bits of resolution, or quantization, will be able to capture a signal with more detail or fidelity. Thus, a video digitizer with 12 bits of resolution will capture 4 times as much detail as one with 10 bits.

Blanking

The Horizontal and Vertical blanking intervals of a television signal refer to the time periods between lines and between fields. No picture information is transmitted during these times, which are required in CRT displays to allow the electron beam to be repositioned for the start of the next line or field. They are also used to carry synchronizing pulses which are used in transmission and recovery of the image. Although some of these needs are disappearing, the intervals themselves are retained for compatibility purposes. They have turned out to be very useful for the transmission of additional content, such as teletext and embedded audio.

CAV

Component Analog Video. This is a convenient shorthand form, but it is subject to confusion. It is sometimes used to mean ONLY color difference component formats (SMPTE or Beta), and other times to include RGB format. In any case, a CAV signal will always require 3 connectors – either Y/R-Y/B-Y, or R/G/B.

Checkfield

A Checkfield signal is a special test signal that stresses particular aspects of serial digital transmission. The performance of the Phase Locked-Loops (PLLs) in an SDI receiver must be able to tolerate long runs of 0's and 1's. Under normal conditions, only very short runs of these are produced due to a scrambling algorithm that is used. The Checkfield, also referred to as the Pathological test signal, will "undo" the scrambling and cause extremely long runs to occur. This test signal is very useful for testing transmission paths.

Chroma

The color or chroma content of a signal, consisting of the hue and saturation of the image. See also Color Difference.

Component

In a component video system, the totality of the image is carried by three separate but related components. This method provides the best image fidelity with the fewest artifacts, but it requires three independent transmission paths (cables). The commonly used component formats are Luminance and Color Difference (Y/Pr/Pb), and RGB. It was far too unwieldy in the early days of color television to even consider component transmission.

Composite

Composite television dates back to the early days of color transmission. This scheme encodes the color difference information onto a color subcarrier. The instantaneous phase of the subcarrier is the color's hue, and the amplitude is the color's saturation or intensity. This subcarrier is then added onto the existing luminance video signal. This trick works because the subcarrier is set at a high enough frequency to leave spectrum for the luminance information. But it is not a seamless matter to pull

the signal apart again at the destination in order to display it or process it. The resultant artifacts of dot crawl (also referred to as chroma crawl) are only the most obvious result. Composite television is the most commonly used format throughout the world, either as PAL or NTSC. It is also referred to as Encoded video.

Color Difference

Color Difference systems take advantage of the details of human vision. We have more acuity in our black and white vision than we do in color. This means that we need only the luminance information to be carried at full bandwidth, we can scrimp on the color channels. In order to do this, RGB information is converted to carry all of the luminance (Y is the black and white of the scene) in a single channel. The other two channels are used to carry the "color difference". Noted as B-Y and R-Y, these two signals describe how a particular pixel "differs" from being purely black and white. These channels typically have only half the bandwidth of the luminance.

Decibel (dB)

The decibel is a unit of measure used to express the ratio in the amplitude or power of two signals. A difference of 20 dB corresponds to a 10:1 ratio between two signals, 6 dB is approximately a 2:1 ration. Decibels add while the ratios multiply, so 26 dB is a 20:1 ratio, and 14 dB is a 5:1 ratio. There are several special cases of the dB scale, where the reference is implied. Thus, dBm refers to power relative to 1 milliwatt, and dBu refers to voltage relative to .775V RMS. The original unit of measure was the Bel (10 times bigger), named after Alexander Graham Bell.

dBFS

In Digital Audio systems, the largest numerical value that can be represented is referred to as Full Scale. No values or audio levels greater than FS can be reproduced because they would be clipped. The nominal operating point (roughly corresponding to 0 VU) must be set below FS in order to have headroom for audio peaks. This operating point is described relative to FS, so a digital reference level of -20 dBFS has 20 dB of headroom before hitting the FS clipping point.

DVI

Digital Visual Interface. DVI-I (integrated) provides both digital and analog connectivity. The larger group of pins on the connector are digital while the four pins on the right are analog.

EDH

Error Detection and Handling is a method to verify proper reception of an SDI or HD-SDI signal at the destination. The originating device inserts a data packet in the vertical interval of the SDI signal and every line of the HD signal which contains a checksum of the entire video frame. This checksum is formed by adding up the numerical values of all of the samples in the frame, using a complex formula. At the destination this same formula is applied to the incoming video and the resulting value is compared to the one included in the transmission. If they match, then the content has all arrived with no errors. If they don't, then an error has occurred.

Embedded Audio

Digital Audio can be carried along in the same bitstream as an SDI or HD-SDI signal by taking advantage of the gaps in the transmission which correspond to the horizontal and vertical intervals

of the television waveform. This technique can be very cost effective in transmission and routing, but can also add complexity to signal handling issues because the audio content can no longer be treated independently of the video.

Eye Pattern

To analyze a digital bitstream, the signal can be displayed visually on an oscilloscope by triggering the horizontal timebase with a clock extracted from the stream. Since the bit positions in the stream form a very regular cadence, the resulting display will look like an eye – an oval with slightly pointed left and right ends. It is easy to see from this display if the eye is “open”, with a large central area that is free of negative or positive transitions, or “closed” where those transitions are encroaching toward the center. In the first case, the open eye indicates that recovery of data from the stream can be made reliably and with few errors. But in the closed case data will be difficult to extract and bit errors will occur. Generally it is jitter in the signal that is the enemy of the eye.

Frame Sync

A Frame Synchronizer is used to synchronize the timing of a video signal to coincide with a timing reference (usually a color black signal that is distributed throughout a facility). The synchronizer accomplishes this by writing the incoming video into a frame buffer memory under the timing direction of the sync information contained in that video. Simultaneously the memory is being read back by a timing system that is genlocked to a house reference. As a result, the timing or alignment of the video frame can be adjusted so that the scan of the upper left corner of the image is happening simultaneously on all sources. This is a requirement for both analog and digital systems in order to perform video effects or switch glitch-free in a router. Frame synchronization can only be performed within a single television line standard. A synchronizer will not convert an NTSC signal to a PAL signal, it takes a standards converter to do that.

Frequency Response

A measurement of the accuracy of a system to carry or reproduce a range of signal frequencies. Similar to Bandwidth.

H.264

The latest salvo in the compression wars is H.264 which is also known as MPEG-4 Part 10. MPEG-4 promises good results at just half the bit rate required by MPEG-2.

HD

High Definition. This two letter acronym has certainly become very popular. Here we thought it was all about the pictures – and the radio industry stole it.

HDMI

The High Definition Multimedia Interface comes to us from the consumer marketplace where it is becoming the de facto standard for the digital interconnect of display devices to audio and video sources. It is an uncompressed, all-digital interface that transmits digital video and eight channels of digital audio. HDMI is a bit serial interface that carries the video content in digital component form over multiple twisted-pairs. HDMI is closely related to the DVI interface for desktop computers and their displays.

IEC

The International Electrotechnical Commission provides a wide range of worldwide standards. They have provided standardization of the AC power connection to products by means of an IEC line cord. The connection point uses three flat contact blades in a triangular arrangement, set in a rectangular connector. The IEC specification does not dictate line voltage or frequency. Therefore, the user must take care to verify that a device either has a universal input (capable of 90 to 230 volts, either 50 or 60 Hz), or that a line voltage switch, if present, is set correctly.

Interlace

Human vision can be fooled to see motion by presenting a series of images, each with a small change relative to the previous image. In order to eliminate the flicker, our eyes need to see more than 30 images per second. This is accomplished in television systems by dividing the lines that make up each video frame (which run at 25 or 30 frames per second) into two fields. All of the odd-numbered lines are transmitted in the first field, the even-numbered lines are in the second field. In this way, the repetition rate is 50 or 60 Hz, without using more bandwidth. This trick has worked well for years, but it introduces other temporal artifacts. Motion pictures use a slightly different technique to raise the repetition rate from the original 24 frames that make up each second of film—they just project each one twice.

IRE

Video level is measured on the IRE scale, where 0 IRE is black, and 100 IRE is full white. The actual voltages that these levels correspond to can vary between formats.

ITU-R 601

This is the principal standard for standard definition component digital video. It defines the luminance and color difference coding system that is also referred to as 4:2:2. The standard applies to both PAL and NTSC derived signals. They both will result in an image that contains 720 pixels horizontally, with 486 vertical pixels in NTSC, and 576 vertically in PAL. Both systems use a sample clock rate of 27 MHz, and are serialized at 270 Mb/s.

Jitter

Serial digital signals (either video or audio) are subject to the effects of jitter. This refers to the instantaneous error that can occur from one bit to the next in the exact position of each digital transition. Although the signal may be at the correct frequency on average, in the interim it varies. Some bits come slightly early, others come slightly late. The measurement of this jitter is given either as the amount of time uncertainty or as the fraction of a bit width. For 270 Mb/s SD video, the allowable jitter is 740 picoseconds, or 0.2 UI (Unit Interval – one bit width). For 1.485 Gb/s HD, the same 0.2UI spec corresponds to just 135 pico seconds.

Luminance

The “black & white” content of the image. Human vision had more acuity in luminance, so television systems generally devote more bandwidth to the luminance content. In component systems, the luminance is referred to as Y.

MPEG

The Moving Picture Experts Group is an industry group that develops standards for the compression of moving pictures for television. Their work is an on-going effort. The understanding of image processing and information theory is constantly expanding. And the raw bandwidth of both the hardware and software used for this work is ever increasing. Accordingly, the compression methods available today are far superior to the algorithms that originally made the real-time compression and decompression of television possible. Today, there are many variations of these techniques, and the term MPEG has to some extent become a broad generic label.

Metadata

This word comes from the Greek, meta means 'beyond' or 'after'. When used as a prefix to 'data', it can be thought of as 'data about the data'. In other words, the metadata in a data stream tells you about that data – but it is not the data itself. In the television industry, this word is sometimes used correctly when, for example, we label as metadata the timecode which accompanies a video signal. That timecode tells you something about the video, i.e. when it was shot, but the timecode in and of itself is of no interest. But in our industry's usual slovenly way in matters linguistic, the term metadata has also come to be used to describe data that is associated with the primary video in a datastream. So embedded audio will (incorrectly) be called metadata when it tells us nothing at all about the pictures. Oh well.

Multi-mode

Multi-mode fibers have a larger diameter core than single mode fibers (either 50 or 62.5 microns compared to 9 microns), and a correspondingly larger aperture. It is much easier to couple light energy into a multi-mode fiber, but internal reflections will cause multiple "modes" of the signal to propagate down the fiber. This will degrade the ability of the fiber to be used over long distances. See also Single Mode.

NTSC

The color television encoding system used in North America was originally defined by the National Television Standards Committee. This American standard has also been adopted by Canada, Mexico, Japan, Korea, and Taiwan. (This standard is referred to disparagingly as Never Twice Same Color.)

Optical

An optical interface between two devices carries data by modulating a light source. This light source is typically a laser or laser diode (similar to an LED) which is turned on and off at the bitrate of the datastream. The light is carried from one device to another through a glass fiber. The fiber's core acts as a waveguide or lightpipe to carry the light energy from one end to another. Optical transmission has two very significant advantages over metallic copper cables. Firstly, it does not require that the two endpoint devices have any electrical connection to each other. This can be very advantageous in large facilities where problems with ground loops appear. And secondly, and most importantly, an optical interface can carry a signal for many kilometers or miles without any degradation or loss in the recovered signal. Copper is barely useful at distances of just 1000 feet.

Oversampling

A technique to perform digital sampling at a multiple of the required sample rate. This has the advantage of raising the Nyquist Rate (the maximum frequency which can be reproduced by a given sample rate) much higher than the desired passband. This allows more easily realized anti-aliasing filters.

PAL

During the early days of color television in North America, European broadcasters developed a competing system called Phase Alternation by Line. This slightly more complex system is better able to withstand the differential gain and phase errors that appear in amplifiers and transmission systems. Engineers at the BBC claim that it stands for Perfection At Last.

Pathological Test Pattern – see Checkfield

Progressive

An image scanning technique which progresses through all of the lines in a frame in a single pass. Computer monitors all use progressive displays. This contrasts to the interlace technique common to television systems.

Return Loss

An idealized input or output circuit will exactly match its desired impedance (generally 75 ohms) as a purely resistive element, with no reactive (capacitive or inductive) elements. In the real world, we can only approach the ideal. So, our real inputs and outputs will have some capacitance and inductance. This will create impedance matching errors, especially at higher frequencies. The Return Loss of an input or output measures how much energy is returned (reflected back due to the impedance mismatch). For digital circuits, a return loss of 15 dB is typical. This means that the energy returned is 15 dB less than the original signal. In analog circuits, a 40 dB figure is expected.

RGB

RGB systems carry the totality of the picture information as independent Red, Green, and Blue signals. Television is an additive color system, where all three components add to produce white. Because the luminance (or detail) information is carried partially in each of the RGB channels, all three must be carried at full bandwidth in order to faithfully reproduce an image.

ScH Phase

Used in composite systems, ScH Phase measures the relative phase between the leading edge of sync on line 1 of field 1 and a continuous subcarrier sinewave. Due to the arithmetic details of both PAL and NTSC, this relationship is not the same at the beginning of each frame. In PAL, the pattern repeats every 4 frames (8 fields) which is also known as the Bruch Blanking sequence. In NTSC, the repeat is every 2 frames (4 fields). This creates enormous headaches in editing systems and the system timing of analog composite facilities.

SDI

Serial Digital Interface. This term refers to inputs and outputs of devices that support serial digital component video. This could refer to standard definition at 270 Mb/s, HD SDI or High Definition Serial Digital video at 1.485 Gb/s, or to the newer 3G standard of High Definition video at 2.97 Gb/s.

SMPTE

The Society of Motion Picture and Television Engineers is a professional organization which has done tremendous work in setting standards for both the film and television industries. The term "SMPTE" is also shorthand for one particular component video format - luminance and color difference.

Single Mode

A Single mode (or mono mode) optical fiber carries an optical signal on a very small diameter (9 micron) core surrounded with cladding. The small diameter means that no internally reflected lightwaves will be propagated. Thus only the original "mode" of the signal passes down the fiber. A single mode fiber used in an optical SDI system can carry a signal for up to 20 kilometers. Single mode fibers require particular care in their installation due to the extremely small optical aperture that they present at splice and connection points. See also Multi-mode.

TBC

A Time Base Corrector is a system to reduce the Time Base Error in a signal to acceptable levels. It accomplishes this by using a FIFO (First In, First Out) memory. The incoming video is written into the memory using its own jittery timing. This operation is closely associated with the actual digitization of the analog signal because the varying position of the sync timing must be mimicked by the sampling function of the analog to digital converter. A second timing system, genlocked to a stable reference, is used to read the video back out of the memory. The memory acts as a dynamically adjusting delay to smooth out the imperfections in the original signal's timing. Very often a TBC will also function as a Frame Synchronizer. See also Frame Sync.

Time Base Error

Time base error is present when there is excessive jitter or uncertainty in the line to line output timing of a video signal. This is commonly associated with playback from video tape recorders, and is particularly severe with consumer type heterodyne systems like VHS. Time base error will render a signal unusable for broadcast or editing purposes.

Timecode

Timecode, a method to uniquely identify and label every frame in a video stream, has become one of the most recognized standards ever developed by SMPTE. It uses a 24 hour clock, consisting of hours, minutes, seconds, and television frames. Originally recorded on a spare audio track, this 2400 baud signal was a significant contributor to the development of video tape editing. We now refer to this as LTC or Longitudinal Time Code because it was carried along the edge of the tape. This allowed it to be recovered in rewind and fast forward when the picture itself could not. Timecode continues to be useful today and is carried in the vertical interval as VITC, and as a digital packet as DVITC. Timecode is the true metadata.

Tri-Level Sync

For many, many years, television systems used composite black as a genlock reference source. This was a natural evolution from analog systems to digital implementations. With the advent of High Definition television, with even higher data rates and tighter jitter requirements, problems with this legacy genlock signal surfaced. Further, a reference signal with a 50 or 60 Hz frame rate was useless with 24 Hz HD systems running at film rates. Today we can think of composite black as a bi-level sync signal – it has two levels, one at sync tip and one at blanking. For HD systems, Tri-Level Sync, which has the same blanking level (at ground) of bi-level sync, but the sync pulse now has both a negative and a positive element. This keeps the signal symmetrically balanced so that its DC content is zero. And it also means that the timing pickoff point is now at the point where the signal crosses blanking and is no longer subject to variation with amplitude. This makes Tri-Level Sync a much more robust signal and one which can be delivered with less jitter.

USB

The Universal Serial Bus, developed in the computer industry to replace the previously ubiquitous RS-232 serial interface, now appears in many different forms and with many different uses. It actually forms a small local area network, allowing multiple devices to coexist on a single bus where they can be individually addressed and accessed.

VGA

Video Graphics Array. Traditional 15-pin, analog interface between a PC and monitor.

Word Clock

Use of Word Clock to genlock digital audio devices developed in the audio recording industry. Early digital audio products were interconnected with a massive parallel connector carrying a twisted pair for every bit in the digital audio word. A clock signal, which is a square wave at the audio sampling frequency, is carried on a 75 ohm coaxial cable. Early systems would daisychain this 44.1 or 48 kilohertz clock from one device to another with coax cable and Tee connectors. On the rising edge of this Word Clock these twisted pairs would carry the left channel, while on the falling edge, they would carry the right channel. In most television systems using digital audio, the audio sample clock frequency (and hence the 'genlock' between the audio and video worlds) is derived from the video genlock signal. But products that are purely audio, with no video reference capability, may still require Word Clock.

WSS

Wide Screen Signaling is used in the PAL/625 video standards, both in analog and digital form, to convey information about the aspect ratio and format of the transmitted signal. Carried in the vertical interval, much like closed captioning, it can be used to signal a television receiver to adjust its vertical or horizontal sizing to reflect incoming material. Although an NTSC specification for WSS exists, it never achieved any traction in the marketplace.

YUV

Strictly speaking, YUV does not apply to component video. The letters refer to the Luminance (Y), and the U and V encoding axes using in the PAL composite system. Since the U axis is very close to the B-Y axis, and the V axis is very close to the R-Y axis, YUV is often used as a sort of shorthand for the more long-winded "Y/R-Y/B-Y".

Y/Cr/Cb

In digital component video, the luminance component is Y, and the two color difference signals are Cr (R-Y) and Cb (B-Y).

Y/Pr/Pb

In analog component video, the image is carried in three components. The luminance is Y, the R-Y color difference signal is Pr, and the B-Y color difference signal is Pb.